



University of Kentucky[®]

Procurement Services

REQUEST FOR PROPOSALS

UK-2591.1-4-25 Experiential Graphic Design

ADDENDUM #1

12/20/2024

ATTENTION: This is not an order. Read all instructions, terms, and conditions carefully.

IMPORTANT: RFP AND ADDENDUM MUST BE RECEIVED BY: 01/07/2025 @ 3:00 P.M. LEXINGTON, KY TIME

Offeror should acknowledge receipt of this and any addendum as stated in the Request for Proposal.

ITEM #1: REVISIONS TO ORIGINAL BID DOCUMENTS AND QUESTIONS & ANSWERS

- Please see the enclosed additional information from the project team.

OFFICIAL APPROVAL
UNIVERSITY OF KENTUCKY

12/20/2024

Ken Scott

Ken Scott, Purchasing Officer

SIGNATURE

Typed or Printed Name

BHDP

Date December 17, 2024

Project No. UKX0400

Project UK Barnhart Building Improvements & Addition
Addendum #01

To All Plan Holders

Purpose Modify the Bid Documents

Distribution All Plan Holders
UK Barnhart Building
BHDP Architecture

TO ALL BIDDERS:

This Addendum supplements and amends the original Plans and Specifications and shall be taken into account in preparing proposals and shall become a part of the contract documents.

DRAWING REVISIONS:

1. **On page 10 – A.5 Primary Entry Activation Floor One**
On page 20 – A.7 Entry Activation Floor Two
On page 27 – A.12 Entry Activation Floor Three
On page 41 – A.15 Entry Activation Floor Four
 - a. Clarified wood spec – Natural birch plywood, flat cut, horizontally run
2. **On page 11 – B.1 Destination Branding Floor One**
 - a. Clarified wood spec – Basis of Design: Old World Timber; Reclaimed Wood Wall Panels, Barnwood Skip-planed, Shiplapped, no gap. Sanded to achieve smooth surface, Wood Z-Clipped to wall in panels. Direct printed to reclaimed wood, white ink and color print. Shop drawings required; Reclaimed wood to be reviewed and approved prior to printing.
3. **On page 3 – Materials for indoor use**
 - a. Updated wallcovering spec

Question and Answer:

1. **Elevation D.1 Stair Activation – is this wall drywall or CMU block?**
 - a. Wall is drywall

Sarah Frey
Experiential Graphic Designer
BHDP Architecture
302 W 3rd St UNIT 500
Cincinnati, OH 45202
513-527-0239

Attachments:

- Revised EGD Drawings

BHDP +



UK Barnhart Building
Improvements & Addition
UKX04.00

EGD Bid Doc
10.16.24

ADDENDUM
12.17.24

PROJECT OVERVIEW

CLIENT NAME	UNIVERSITY OF KENTUCKY
PROJECT NAME	UK BARNHART BUILDING IMPROVEMENTS & ADDITION
PROJECT ADDRESS	1398 NICHOLASVILLE RD, LEXINGTON, KY 40508
PROJECT INSTALLATION DATE	QUARTER 1 OF 2026 - COORDINATE WITH CM

BID OVERVIEW

QUESTIONS See solicitation for bid question due dates, submission, and requirements.
DO NOT submit questions directly to BHDP.

BID REQUIREMENTS **Quote shall be itemized** per graphic type, installation, project management fees, shipping, and applicable taxes.

- All bids are required to use bid worksheet, if provided, at RFP.
- All alternates and substitutions shall be described as an additional line item. *See next page for materials compliance information.*
- All quoted costs shall include field verifications and all components, fabrication, submittals and any necessary re-submittals, transportation and shipping costs, permits licenses, and any and all taxes.
- Payment terms required to be submitted with proposals. Negotiation may be necessary prior to release of PO.
- ALL PRICES SHALL BE FIXED AND INCLUDE ESCALATION. BIDDER AGREES TO HOLD PRICING UNTIL INSTALLATION.

FABRICATOR RESPONSIBILITIES

FIELD VERIFICATION OF MEASUREMENTS

All field dimensions in this document are approximate. It is the Fabricator's sole responsibility to field verify all measurements and mounting locations indicated in these documents to ensure accurate and appropriate dimensions. Written notice of any discrepancies, upon field verification, shall be provided to BHDP, at which time additional direction will be given. If discrepancies and/or obstructions are found, Fabricator to notify BHDP immediately and denote the discrepancy with measurements in the site survey.

ON-SITE INSTALLATION COORDINATION

Fabricator's project manager shall coordinate all on-site work with the contract holder.

The fabricator is to examine conditions of areas where graphics are to be installed and notify contract holder in writing of any conditions detrimental to proper and timely completion of work.

For new construction, the General Contractor is responsible for ensuring all wall-mounted obstructions do not conflict with wall graphics / features as noted in the architectural plans.

The General Contractor is required to move any incorrectly installed wall-mounted obstructions that conflict with wall graphics / features at no additional cost to the project.

WARRANTY INFORMATION

These drawings make recommendations as to materials, performance standards, and fabrication methods but the Fabricator is ultimately responsible for the ensured quality and safety of the final product. Warranty period shall not be less than one (1) year from finished installation, unless otherwise specified. Fabricator shall provide the terms by which they guarantee their fabrications and installation, including integrity of materials and workmanship. Repair or replacement of graphics / feature at no additional cost if graphics fail within the warranty period.

PERMITTING & DRAWINGS

If required for permitting, final shop drawings to be stamped by an Engineer licensed in the state of the project location. Detailed, engineered shop drawings necessary for any sign type, wall graphic / feature for each sign type are to be submitted as an electronic PDF. Shop drawings are required to denote material seam locations on sign faces, structural elements, and fastening details. Awarded fabricator is responsible for submission and coordination of all required Authority Having Jurisdiction (AHJ) submittals and approvals. Fabricator shall attend as required any in person meetings with AHJ or its Council as required at no additional cost.

MATERIALS FOR INDOOR USE

Unless otherwise indicated, assume the use of the following materials. If an alternate material is recommended, fabricator to provide sample for comparison to BHDP at no additional cost.

Where specific products or items are called out by BHDP to be utilized, Fabricator shall assume the use of said product or item in Fabricator's primary quotation

- **ACRYLIC:** Acrylite brand acrylic sheet. Non-glare unless otherwise noted.
- **EXPANDED PLASTIC SHEET:** Sintra brand PVC sheet
- **ALUMINUM:** Clear coat all unfinished/non-anodized aluminum pieces.
When grain is visible, horizontal brushed finish unless noted.
- **ACM:** Dibond brand. Horizontal brushed finish unless noted.
- **VINYL:** 3M high-performance vinyl.
- **WALLCOVERING:** Dreamscape Suede wallcovering
- **PAINT (NON ADA):** Unless otherwise noted, finished surfaces will be prepared by GC as represented in the architectural plans prior to EGD installation, and is not in the scope of the fabricator. Paint applied to wall by EGD fabricator is to be Sherwin Williams unless otherwise noted. All signage paint is to be Matthews brand Acrylic Polyurethane, Akzo Nobel's GripGuard brand sign paint. All finishes are semi-gloss unless noted.
- **PAINT (ADA COMPLIANT):** All finishes are satin to maintain ADA compliance.
- **FASTENERS:** To be fabricated from materials that are non-corrosive to either the signage materials or the mounting surface. Where fasteners are not shown, use hidden fasteners.

ALTERNATES / SUBSTITUTIONS

Fabricator may make recommendations for improvement, and any better-suited materials and fabrication methods that vary from the original Design Intent Drawings. If the Fabricator desires to submit an alternate bid that utilizes the substituted product or item, **Fabricator shall make note of the alternate as an additional line item in quotation and provide manufacturer's data sheet supporting equivalent specifications or performance along with the itemized cost savings.**

A sample of the alternative may be required.

ARTWORK

DESIGN INTENT DRAWINGS

Note that this package contains Design Intent Drawings, which are not to be used for fabrication and/or production. All custom designed artwork shall be supplied to Fabricator in digital format (Adobe Creative Cloud files). Purchase of type fonts specified or other software shall be at the Fabricator's expense.

ADA COMPLIANCE

Note that this package contains Design Intent Drawings, which are not to be used for fabrication and/or production. ADA compliance is the responsibility of the Fabricator. If discrepancies with ADA compliance are found, the Fabricator will be responsible for adjusting appropriately and submitting updates to BHDP for final design approval.

PHOTOGRAPHY

Low-res photographic images are for placement only and are not to be used for fabrication. High-resolution photographs will be supplied as separate files by BHDP unless noted.

COLOR

These documents are not intended for color matching. All colors must be matched to PMS color chips or paint code as noted in document OR samples provided to BHDP for review and approval.

PAGE UPDATED
12.12.24

MATERIALS FOR OUTDOOR USE

Unless otherwise indicated, assume the use of the following materials. If an alternate material is recommended, fabricator to provide sample for comparison to BHDP at no additional cost.

Where specific products or items are called out by BHDP to be utilized, Fabricator shall assume the use of said product or item in Fabricator's primary quotation

- **ACRYLIC:** Acrylite brand acrylic sheet or approved similar.
- **EXPANDED PLASTIC SHEET:** Sintra brand PVC sheet or approved similar.
- **ALUMINUM:** Clear Coat all all unfinished/non-anodized aluminum pieces.
When grain is visible, horizontal brushed finish unless noted.
- **VINYL:** 3M high-performance vinyl
Non-reflective: 3M Scotchcal 7000 Series
Reflective: 3M Engineering Grade Reflective Sheeting Series 3200
- **PAINT (NON ADA):** All signage paint is to be Matthews brand Acrylic Polyurethane, Akzo Nobel's GripGuard brand or approved similar sign paint. All finishes are semi-gloss. Steel must be powdercoated or finished with an automotive grade paint to prevent corrosion.
- **ANTI-GRAFFITI COATING:** All anti-graffiti coating is semi-gloss.
- **FASTENERS:** To be fabricated from materials that are non-corrosive to either the signage materials or the mounting surface. Where fasteners are not shown, use hidden fasteners.

ALTERNATES / SUBSTITUTIONS

Fabricator may make recommendations for improvement, and any better-suited materials and fabrication methods that vary from the original Design Intent Drawings. If the Fabricator desires to submit an alternate bid that utilizes the substituted product or item, **Fabricator shall make note of the alternate as an additional line item in quotation and provide manufacturer's data sheet supporting equivalent specifications or performance along with the itemized cost savings.**

A sample of the alternative may be required.

ARTWORK

DESIGN INTENT DRAWINGS

Note that this package contains Design Intent Drawings, which are not to be used for fabrication and/or production. All custom designed artwork shall be supplied to Fabricator in digital format (Adobe Creative Cloud files). Purchase of type fonts specified or other software shall be at the Fabricator's expense.

ADA COMPLIANCE

Note that this package contains Design Intent Drawings, which are not to be used for fabrication and/or production. ADA compliance is the responsibility of the Fabricator. If discrepancies with ADA compliance are found, the Fabricator will be responsible for adjusting appropriately and submitting updates to BHDP for final design approval.

PHOTOGRAPHY

Low-res photographic images are for placement only and are not to be used for fabrication. High-resolution photographs will be supplied as separate files by BHDP unless noted.

COLOR

These documents are not intended for color matching. All colors must be matched to PMS color chips or paint code as noted in document OR samples provided to BHDP for review and approval.

EXPERIENTIAL GRAPHIC DESIGN PLAN FLOOR ONE

LEGEND	
█	A Graphic Activation
█	B Destination Branding
█	C Huddle Room Graphics
█	D Stair Activation
█	E Window Vinyl







EXPERIENTIAL GRAPHIC DESIGN PLAN FLOOR TWO

LEGEND	
■	A Graphic Activation
■	B Destination Branding
■	C Huddle Room Graphics
■	D Stair Activation
■	E Window Vinyl



EXPERIENTIAL GRAPHIC DESIGN PLAN FLOOR THREE

LEGEND	
	A Graphic Activation
	B Destination Branding
	C Huddle Room Graphics
	D Stair Activation
	E Window Vinyl



EXPERIENTIAL GRAPHIC DESIGN PLAN FLOOR FOUR

LEGEND	
█	A Graphic Activation
█	B Destination Branding
█	C Huddle Room Graphics
█	D Stair Activation
█	E Window Vinyl



FLOOR ONE

ELEVATION: A.5 Primary Entry Activation *Floor One*

SCALE: 3/8" = 1'0"

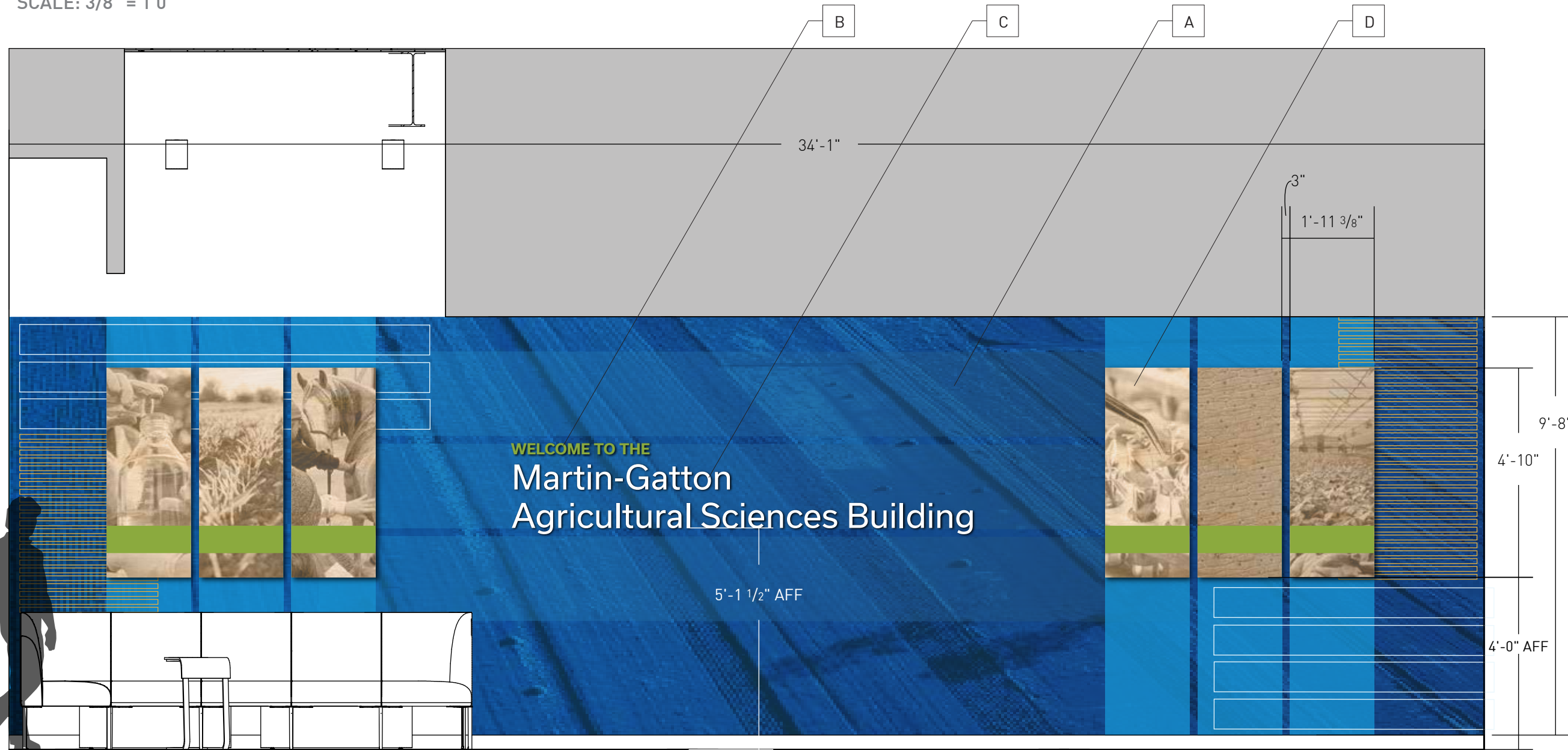

ELEMENT DESCRIPTION:

A
Digitally printed to DreamScape Suede wallcovering

B
1/4" acrylic faces and returns painted to match PMS 2301 C, pin mounted to wall with silicone

C
1/2" acrylic faces and returns painted white, pin mounted to wall with silicone

D
[QTY 6]
1/2" natural birch plywood, flat cut horizontally run. Direct print first surface, white ink underlay and color print. Z-clip to wall with tamper-proof fasteners. Sand to achieve smooth surface

PAGE UPDATED
12.12.24

SAMPLE REQUESTED
2' x 2' Wallcovering
2' x 2' Plywood
1" x 1" Acrylic PMS 2301 C

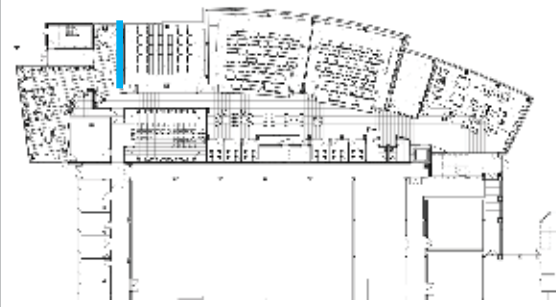

1 Elevation **Graphic Activation**
Scale: 3/8"=1'-0"

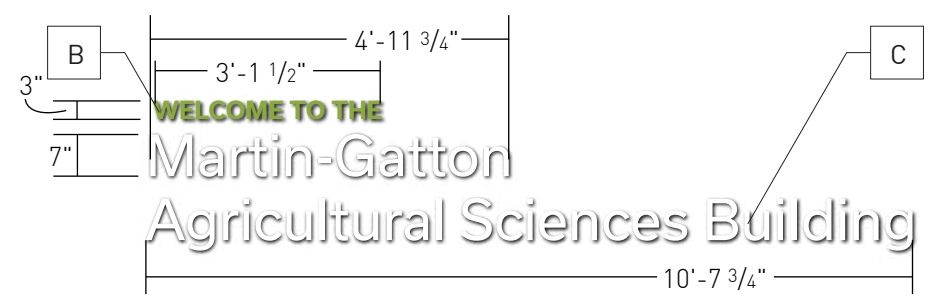

2 Elevation **Element B & C Detail**
Scale: 3/8"=1'-0"

ELEVATION: B.1 Destination Branding *Floor One*

SCALE: 1/2" = 1'-0"



1 Elevation Destination Branding
Scale: 1/2" = 1'-0"

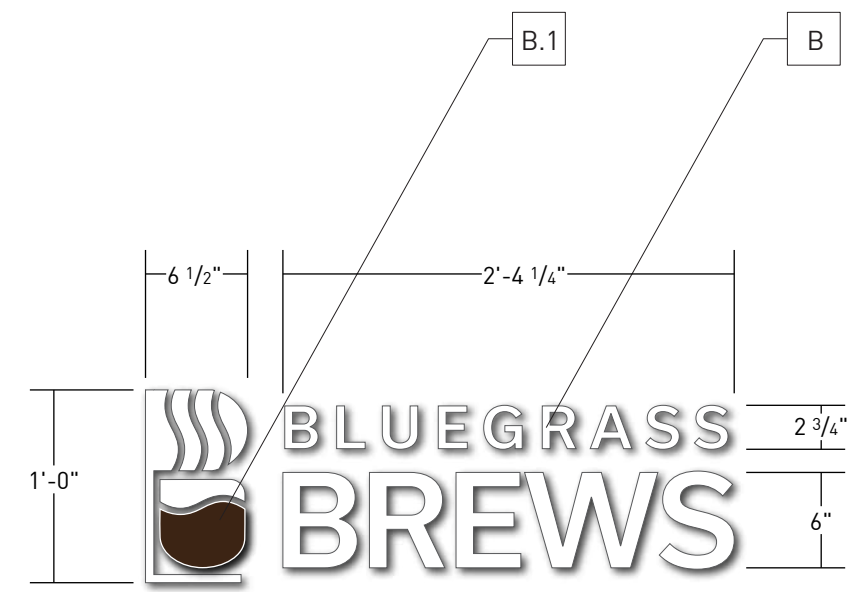

2 Elevation Element B & B.1 Detail
Scale: 1/2" = 1'-0"

ELEMENT DESCRIPTION:

A
Basis of Design: Old World Timber; Reclaimed Wood Wall Panels, Barnwood Skip-planed, Shiplapped, no gap.

Sanded to achieve smooth surface, Wood Z-Clipped to wall in panels. Direct printed to reclaimed wood, white ink and color print.

MAGENTA DASHED LINE INDICATES INDIVIDUAL Z-CLIPPED PANELS

SHOP DRAWINGS REQUIRED; RECLAIMED WOOD TO BE REVIEWED AND APPROVED PRIOR TO PRINTING

B
1/2" acrylic faces and returns painted white, pin mounted to wall with silicone

B.1
1/2" acrylic face painted PMS 463 C and returns painted white, pin mounted to wall with silicone

PAGE UPDATED
12.12.24

SAMPLE REQUESTED
2' x 2' Printed Wood
1" x 1" Acrylic PMS 463 C

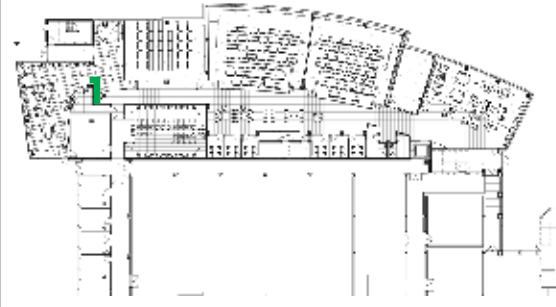

ELEVATION: B.2 Destination Branding *Floor One*

SCALE: 3/8" = 1'0"



ELEMENT DESCRIPTION:

A
1/2" acrylic faces and returns
painted white, pin mounted with
silicone



Rendering for curved soffit reference

① Elevation Destination Branding
Scale: 3/8"=1'-0"

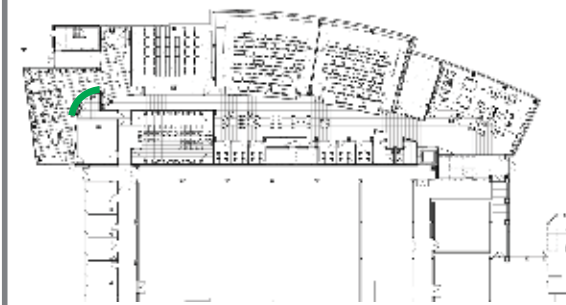

ELEVATION: A.3 Corridor Activation *Floor One*

SCALE: 1/2" = 1'0"

A

22'-4 3/4"

8'-8 5/8"

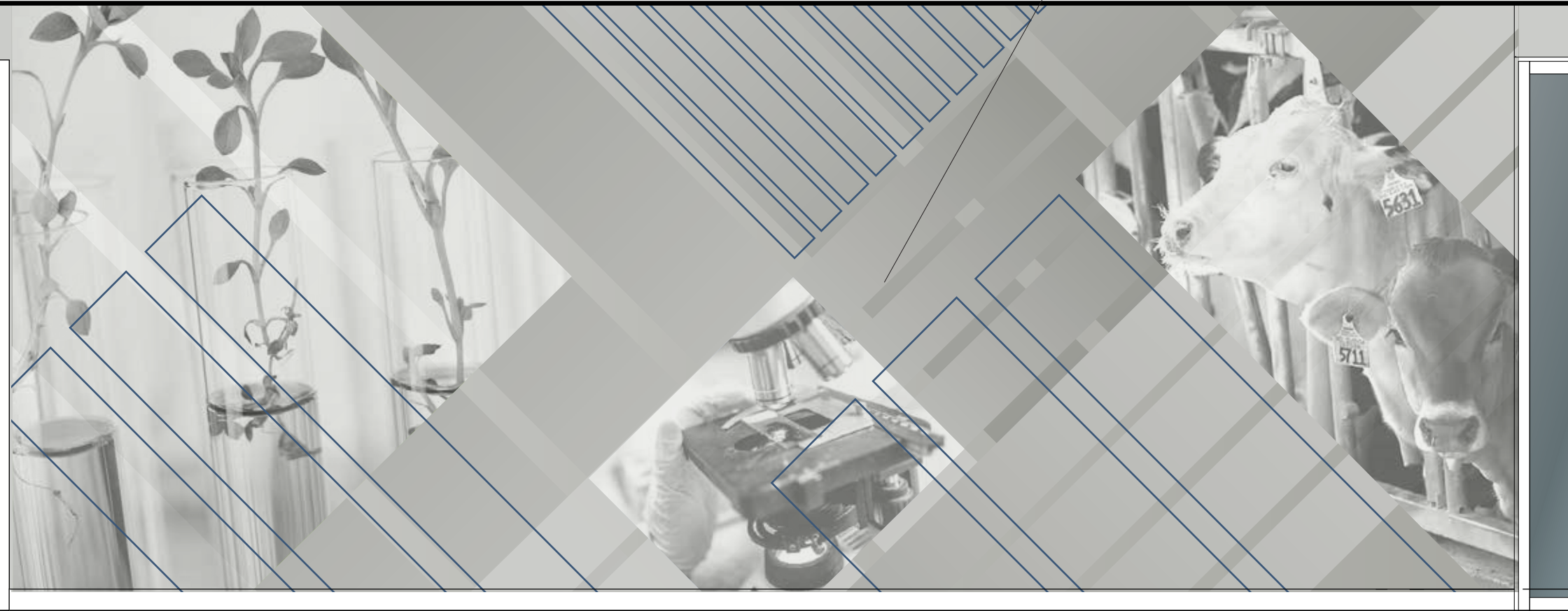
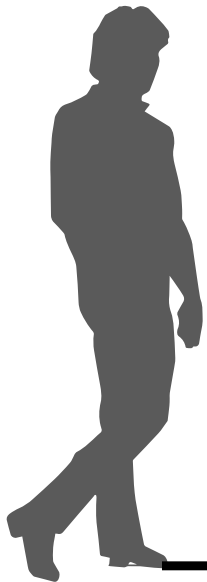

ELEMENT DESCRIPTION:

A
Digitally printed to DreamScape
Suede wallcovering

1 Elevation Graphic Activation
Scale: 1/2"=1'-0"

SAMPLE REQUESTED
2' x 2' Wallcovering

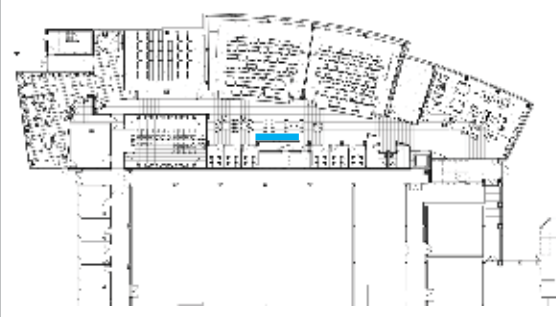

ELEVATION: C.1 - C.6 Huddle Room Graphics *Floor One*

SCALE: 3/8" = 1'-0"

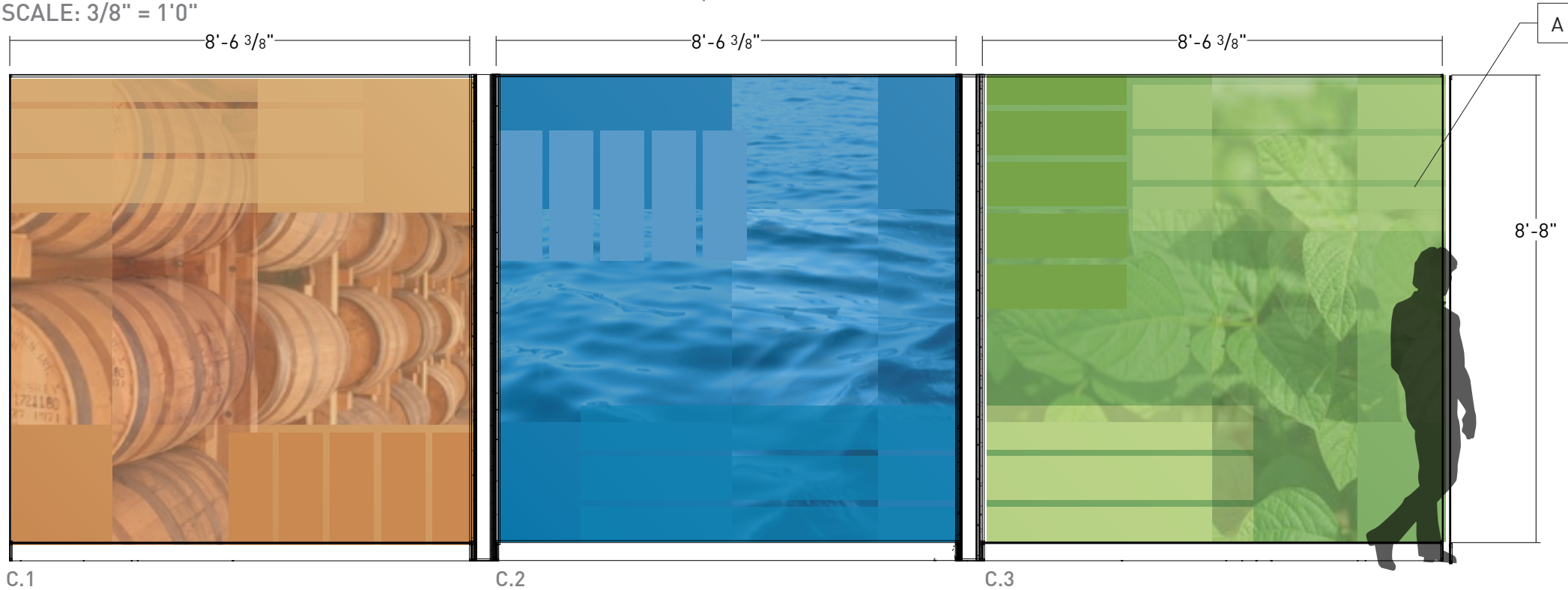

C.1
Elevation Huddle Room Graphics
Scale: 3/8"=1'-0"

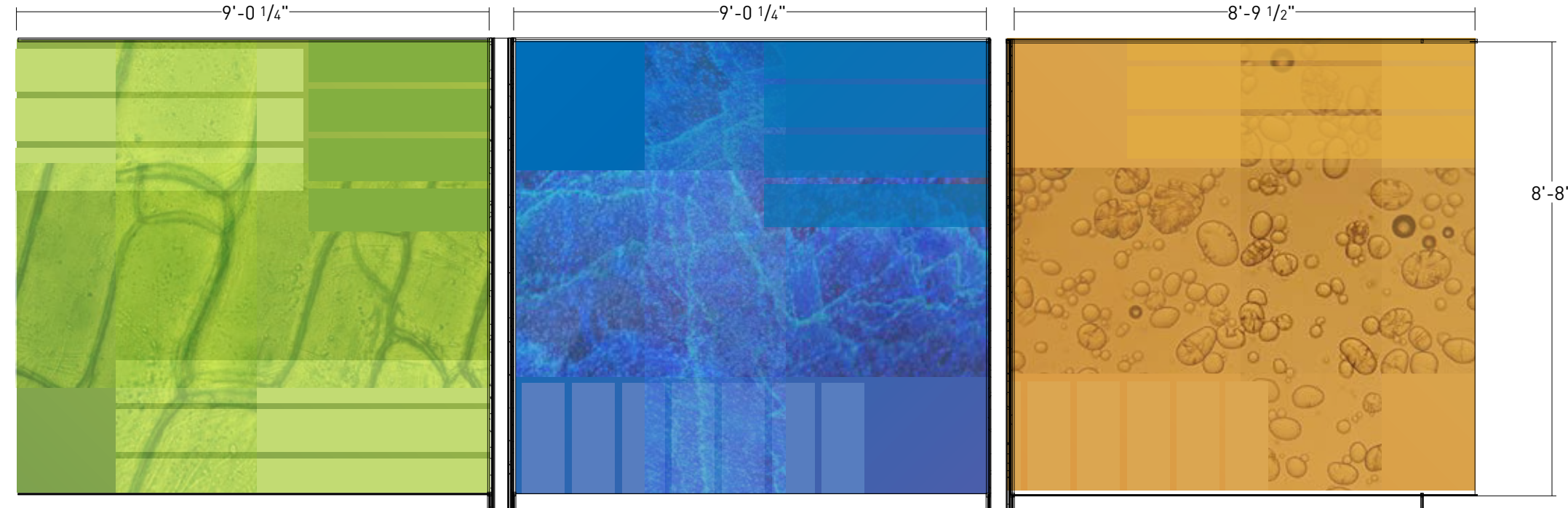

C.4
Elevation Huddle Room Graphics
Scale: 3/8"=1'-0"

ELEMENT DESCRIPTION:

A
Digitally printed to DreamScape
Suede wallcovering

SAMPLE REQUESTED
[QYT 6] 2' x 2' Wallcovering



ELEVATION: E.1 & E.2 Window Vinyl, C.1 – C.6 Donor Plaques *Floor One*

SCALE: 1/8" = 1'-0", 1" = 1'-0"

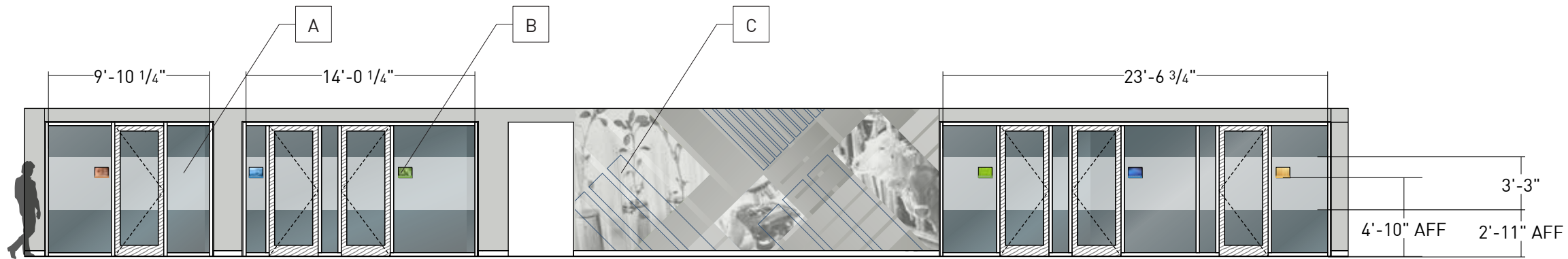

1 Elevation Window Vinyl
Scale: 1/8"=1'-0"



C.1



C.2



C.3

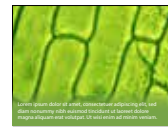

C.4



C.5

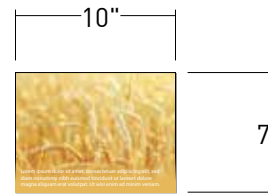

C.6

2 Elevation Element B Detail
Scale: 1"=1'-0"

ELEMENT DESCRIPTION:

A
3M Dusted Crystal Vinyl, applied second surface

B
[QTY 6]
1/2" clear acrylic, printed first surface. Applied to glass with VHB tape, first surface

When sign is applied to glass, add 10" x 7" white vinyl second surface to hide adhesive

C
SEE PAGE 13 FOR DETAILS

SAMPLE REQUESTED
Donor Plaque Mock Up



ELEVATION: E.3 Window Vinyl *Floor One*

SCALE: 3/8" = 1'-0"

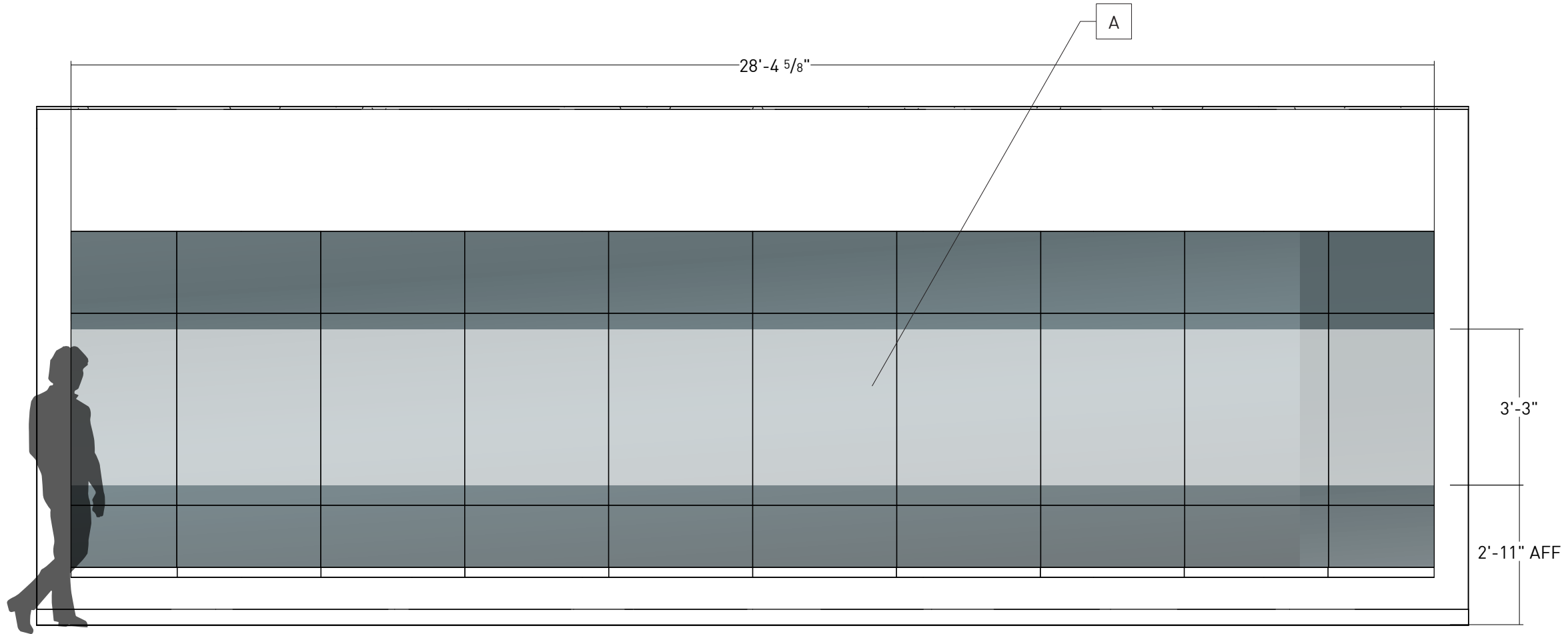

1 Elevation Window Vinyl
Scale: 3/8" = 1'-0"

ELEMENT DESCRIPTION:

A
3M Dusted Crystal Vinyl, applied second surface

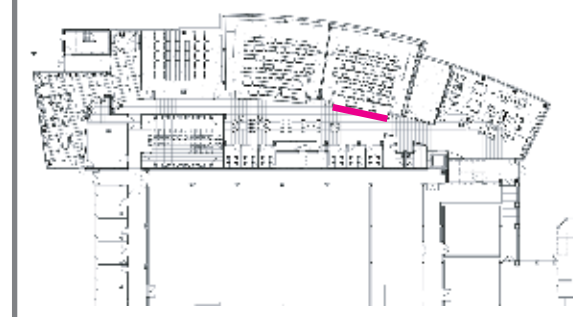

ELEVATION: E.4 Window Vinyl *Floor One*

SCALE: 3/8" = 1'0"

ELEMENT DESCRIPTION:

A
3M Dusted Crystal Vinyl, applied second surface

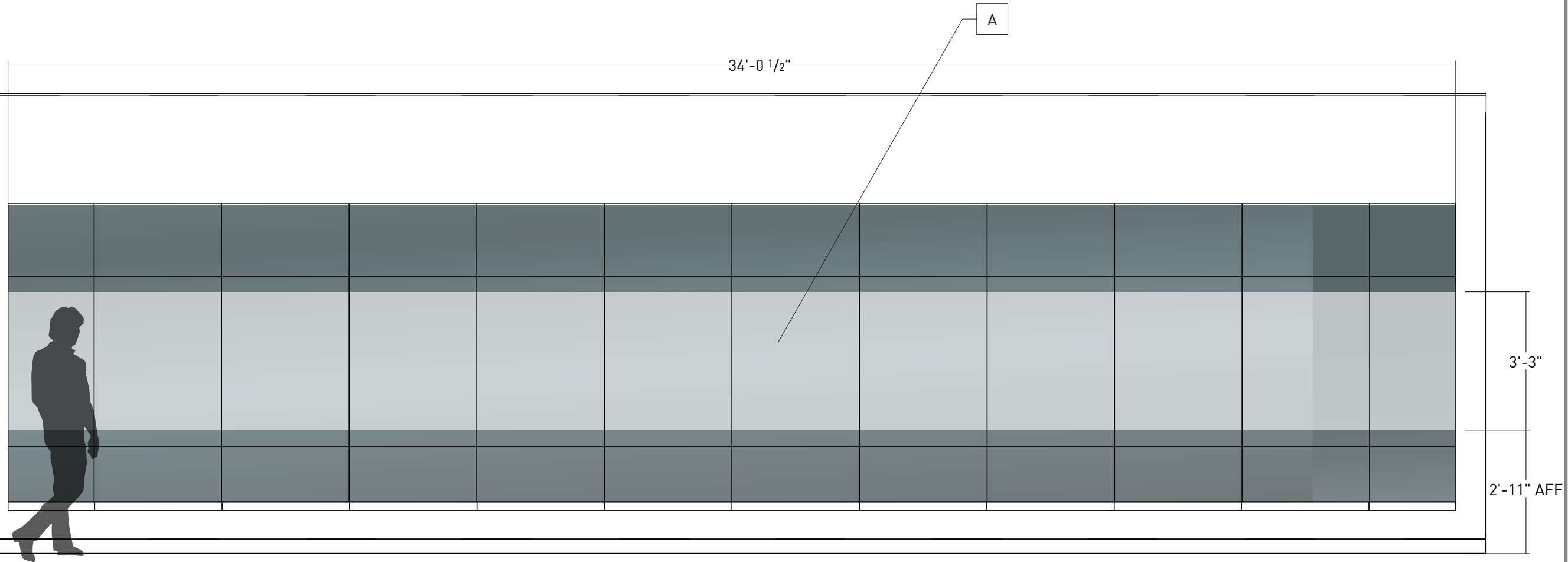

1 Elevation Window Vinyl
Scale: 3/8" = 1'-0"



ELEVATION: E.5 Window Vinyl *Floor One*

SCALE: 3/8" = 1'-0"

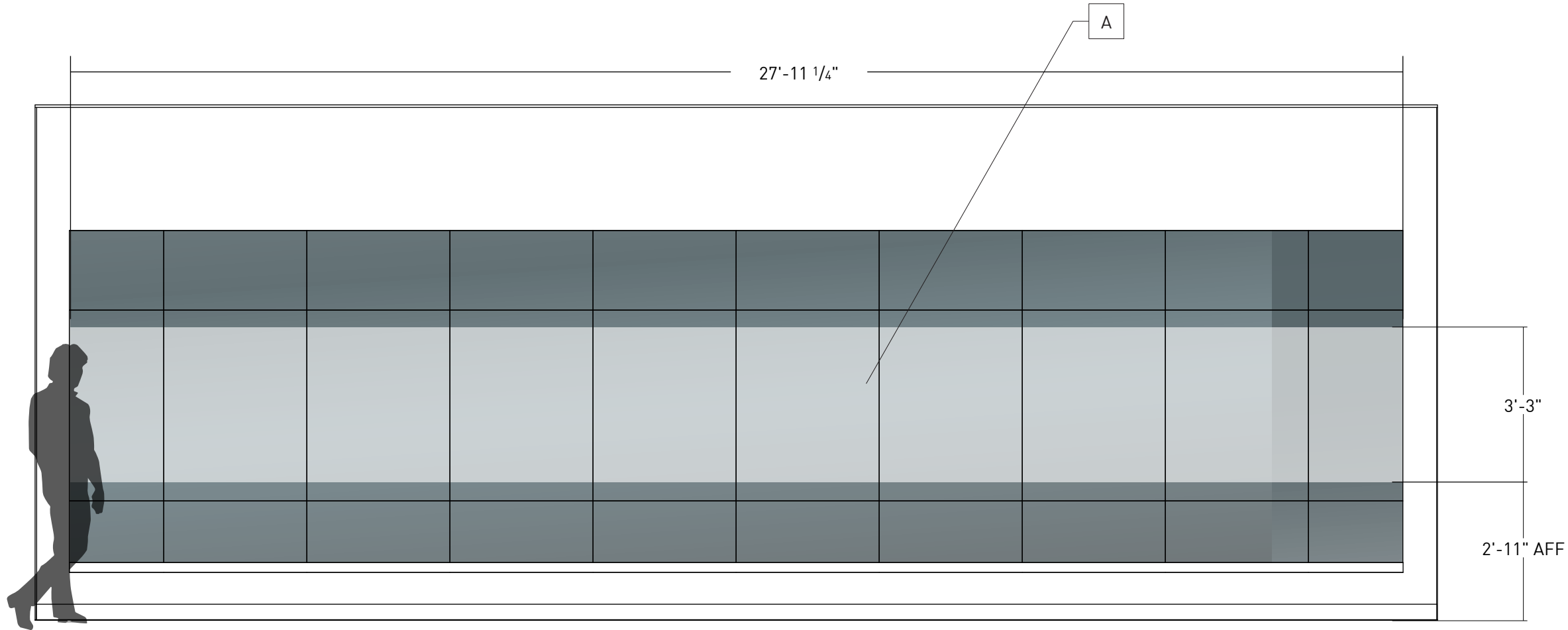

ELEMENT DESCRIPTION:

A
3M Dusted Crystal Vinyl, applied second surface

① Elevation Window Vinyl
Scale: 3/8" = 1'-0"

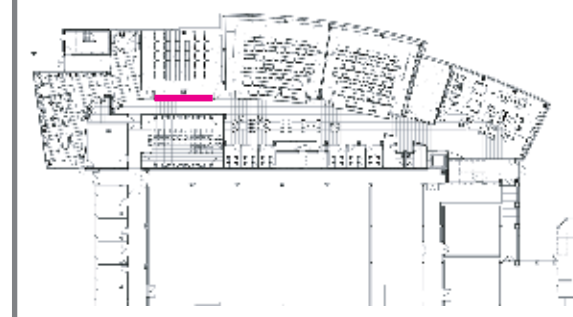

FLOOR TWO

ELEVATION: A.7 Entry Activation *Floor Two*

SCALE: 1/2" = 1'0"



ELEMENT DESCRIPTION:

A
Digitally printed to DreamScape Suede wallcovering

B
[QTY 3]
1/2" natural birch plywood, flat cut horizontally run. Direct print first surface, white ink underlay and color print. Z-clip to wall with tamper-proof fasteners. Sand to achieve smooth surface

C
MONITOR BY OTHERS

PAGE UPDATED
12.12.24

SAMPLE REQUESTED
2' x 2' Wallcovering
Plywood Mock Up



1 Elevation **Graphic Activation**
Scale: 1/2"=1'-0"

ELEVATION: A.8 Corridor Activation *Floor Two*

SCALE: 1/2" = 1'0"

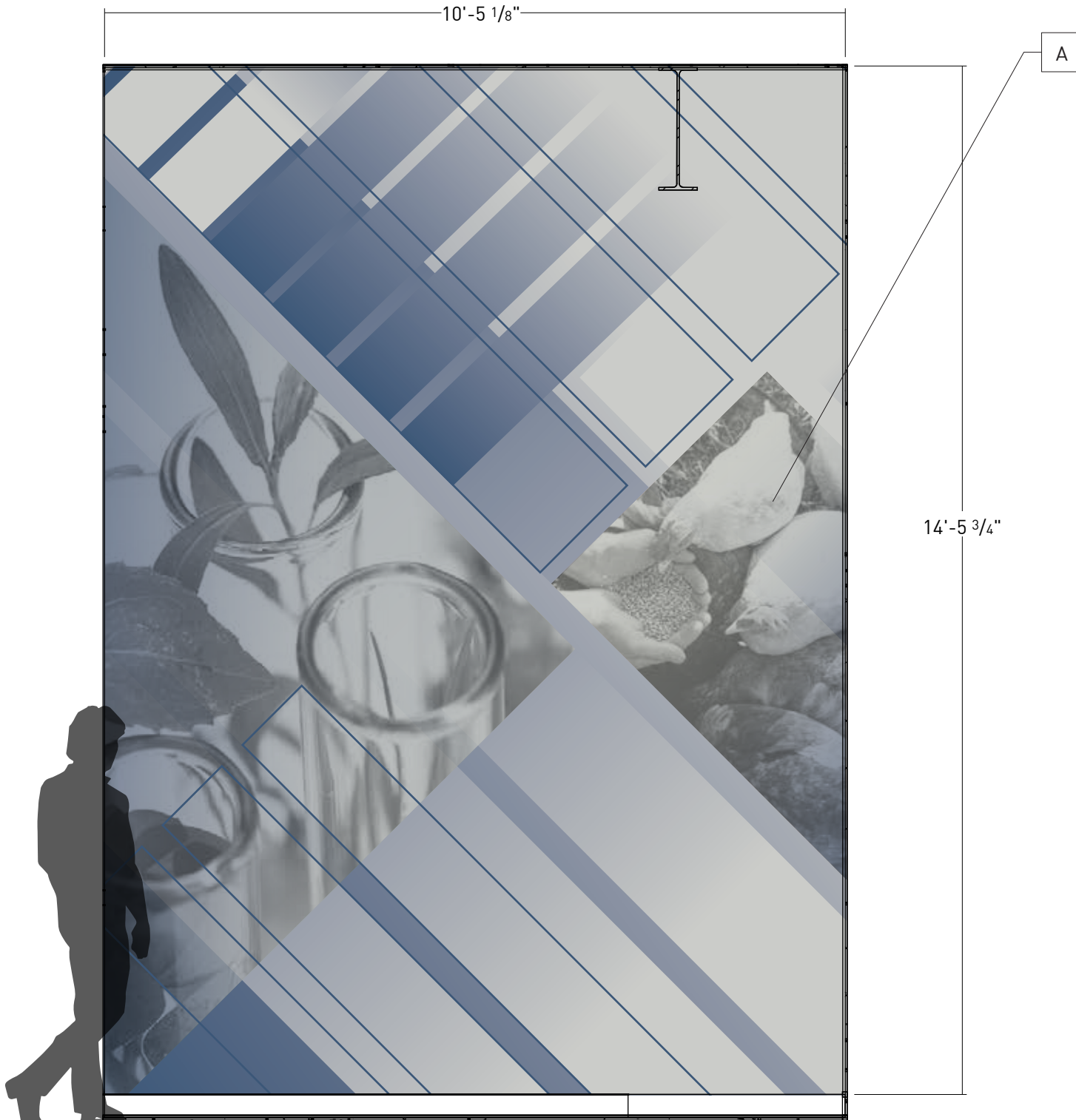

ELEMENT DESCRIPTION:

A
Digitally printed to DreamScape
Suede wallcovering

SAMPLE REQUESTED
2' x 2' Wallcovering



1 Elevation Graphic Activation
Scale: 1/2" = 1'-0"

ELEVATION: C.7 & C.8 Huddle Room Graphics *Floor Two*

SCALE: 1/2" = 1'-0"

ELEMENT DESCRIPTION:

A
Digitally printed to DreamScape
Suede wallcovering

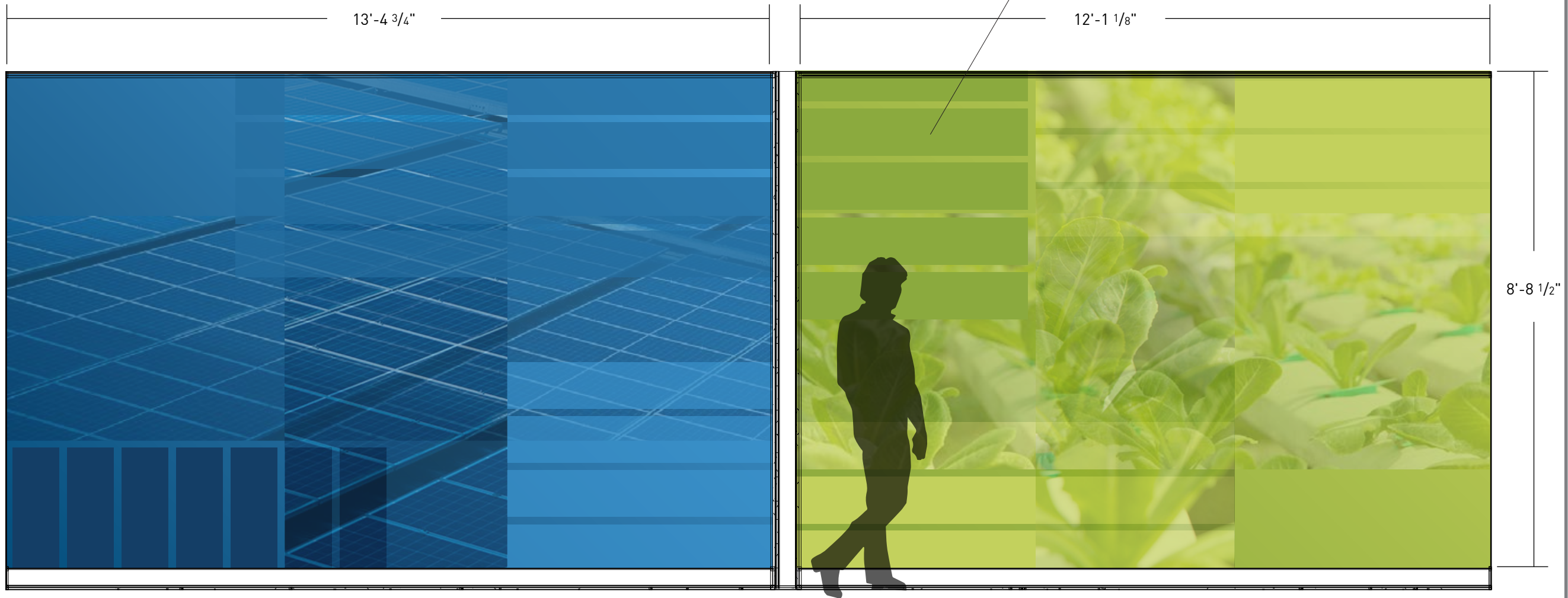

① Elevation C.7 Huddle Room Graphics
Scale: 1/2"=1'-0"

② Elevation C.8 Huddle Room Graphics
Scale: 1/2"=1'-0"



ELEVATION: E.7 – E.9 Window Vinyl *Floor Two*

SCALE: 1/4" = 1'-0"

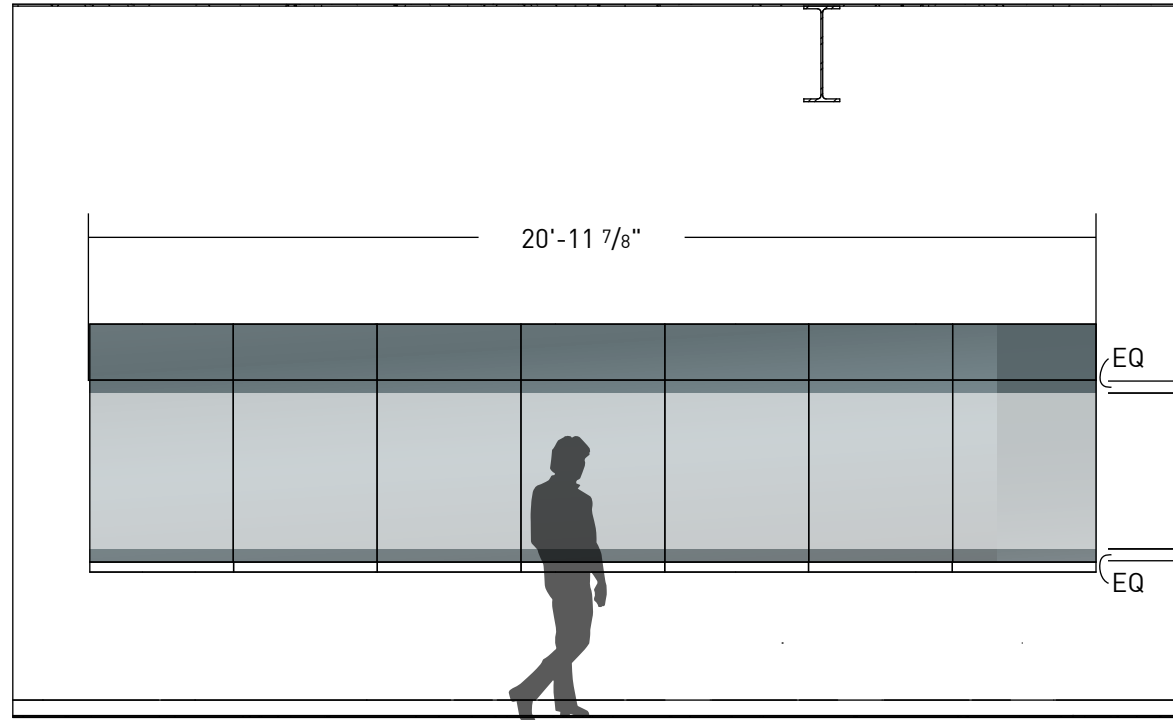

1 Elevation E.7 Window Vinyl
Scale: 1/4" = 1'-0"

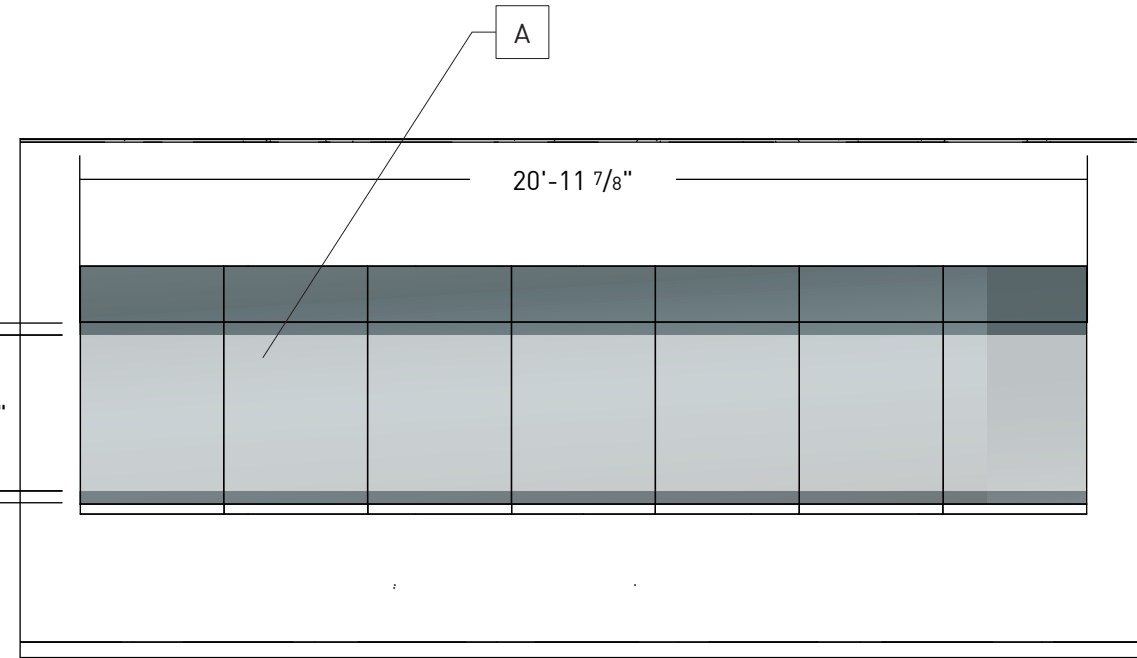

2 Elevation E.8 Window Vinyl
Scale: 1/4" = 1'-0"

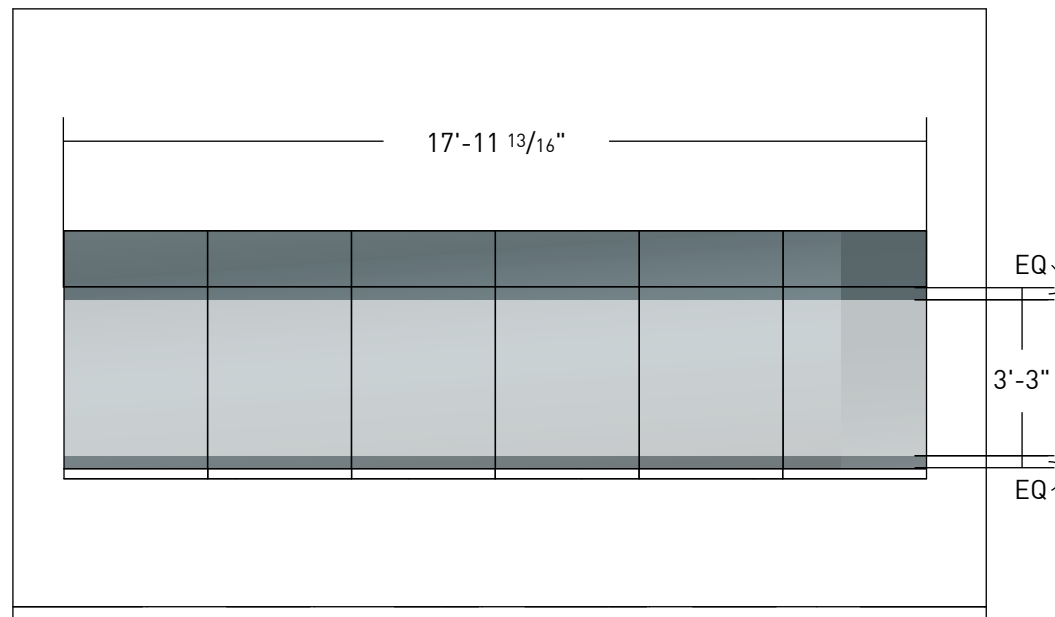

3 Elevation E.9 Window Vinyl
Scale: 1/4" = 1'-0"

ELEMENT DESCRIPTION:

A
3M Dusted Crystal Vinyl, applied second surface



ELEVATION: E.10 & E.11 Window Vinyl, C.7 – C.8 Donor Plaques *Floor Two*

SCALE: 3/8" = 1'-0"

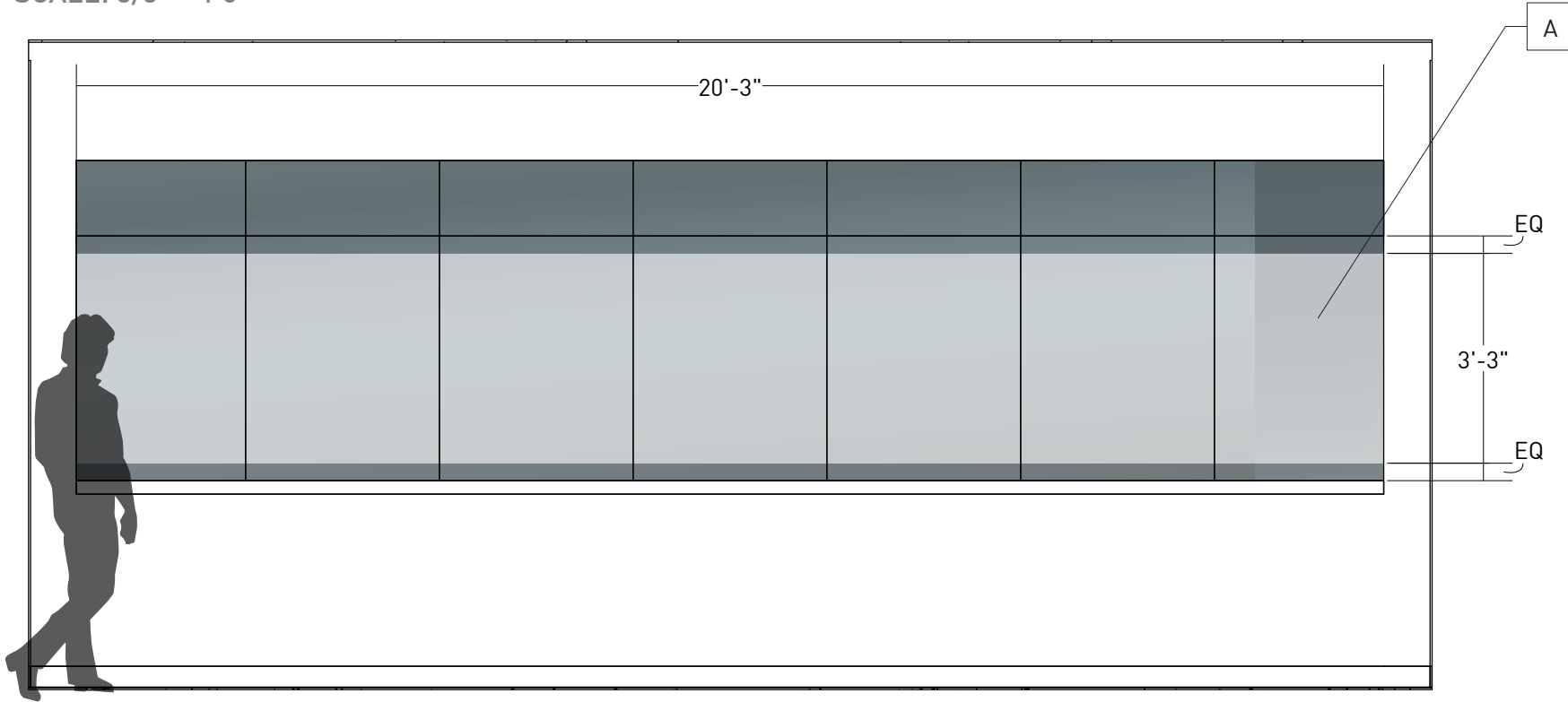

1 Elevation E. 10 Window Vinyl
Scale: 3/8"=1'-0"

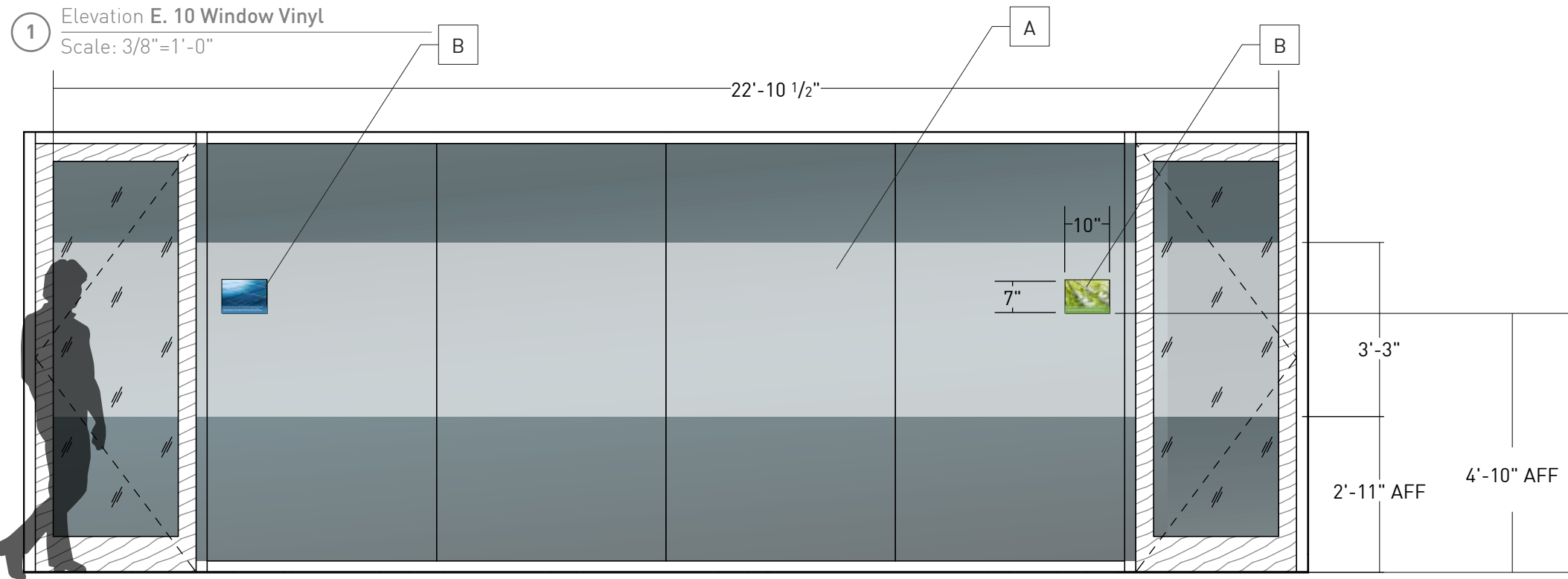

2 Elevation E. 11 Window Vinyl
Scale: 3/8"=1'-0"

ELEMENT DESCRIPTION:

A
3M Dusted Crystal Vinyl, applied second surface

B
[QTY 2]
1/2" clear acrylic, printed first surface. Applied to glass with VHB tape, first surface

When sign is applied to glass, add 10" x 7" white vinyl second surface to hide adhesive



ELEVATION: E.12 Window Vinyl *Floor Two*

SCALE: 3/8" = 1'0"

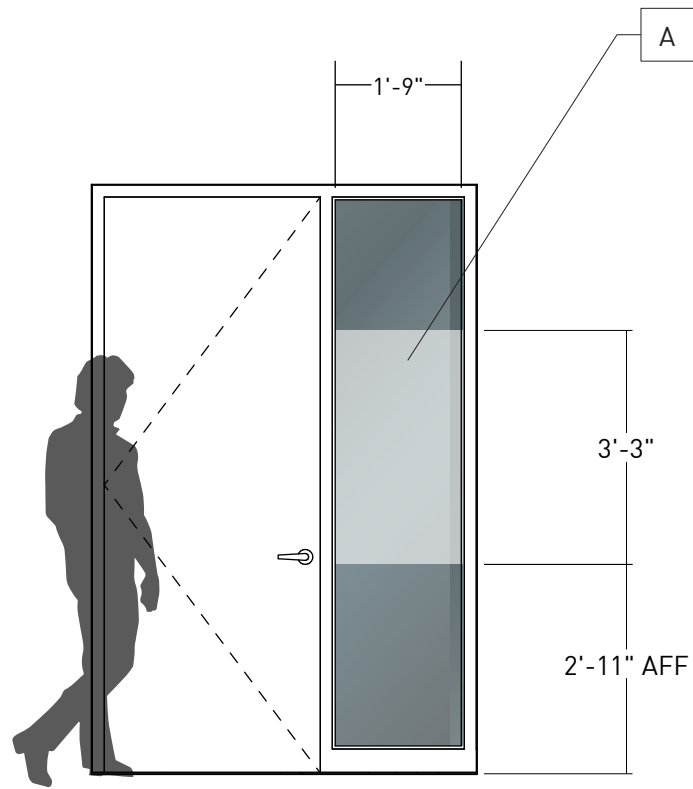

1 Elevation **Window Vinyl**
Scale: 3/8"=1'-0"

ELEMENT DESCRIPTION:

A
3M Dusted Crystal Vinyl, applied second surface



ELEVATION: A.12 Entry Activation *Floor Three*

SCALE: 1/2" = 1'-0"

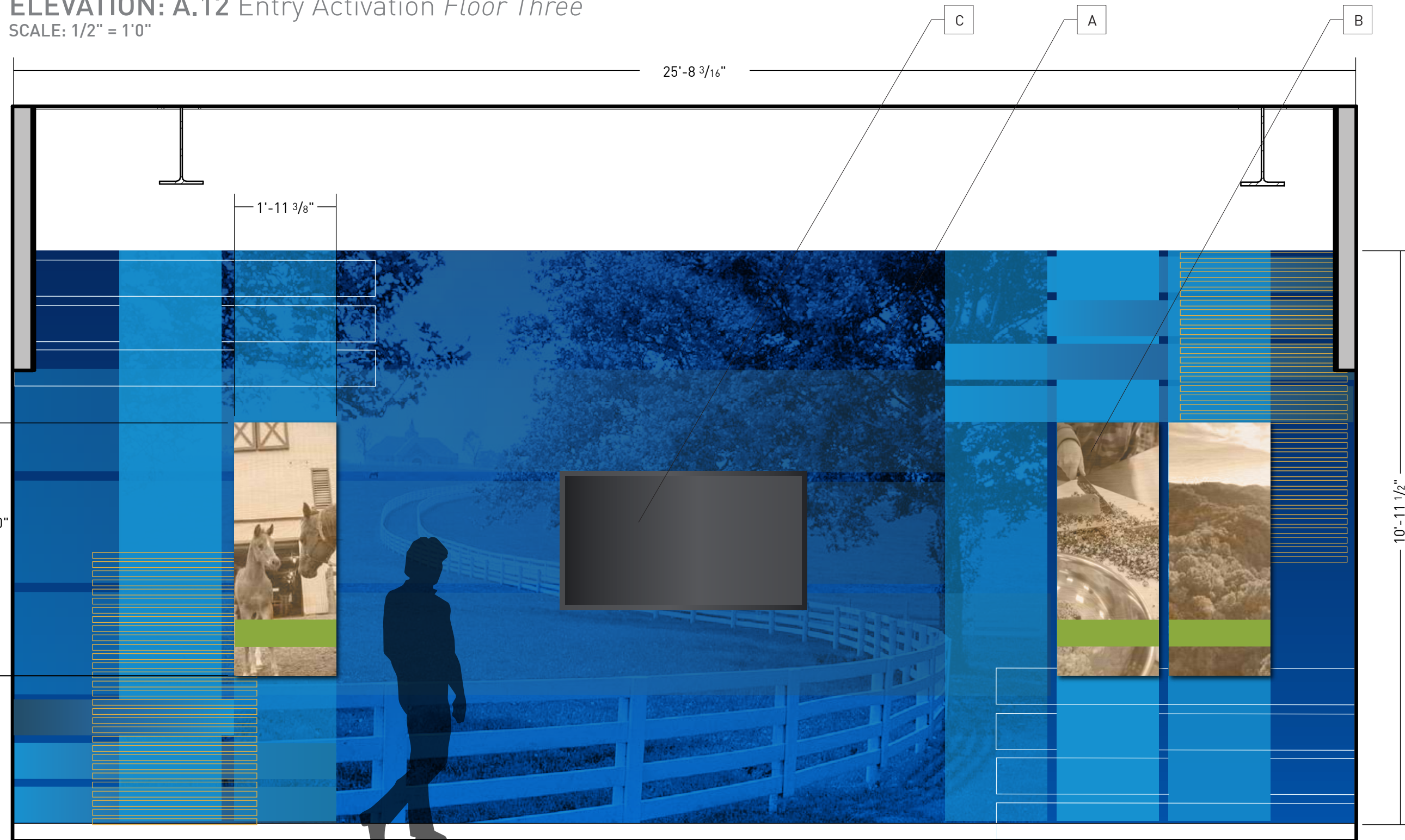

ELEMENT DESCRIPTION:

A
Digitally printed to DreamScape Suede wallcovering

B
[QTY 3]
1/2" natural birch plywood, flat cut horizontally run. Direct print first surface, white ink underlay and color print. Z-clip to wall with tamper-proof fasteners. Sand to achieve smooth surface

C
MONITOR BY OTHERS

PAGE UPDATED
12.12.24

SAMPLE REQUESTED
2' x 2' Wallcovering
2' x 2' Plywood



① Elevation **Graphic Activation**
Scale: 1/2"=1'-0"

ELEVATION: A.11 Corridor Activation *Floor Three*

SCALE: 1/2" = 1'0"

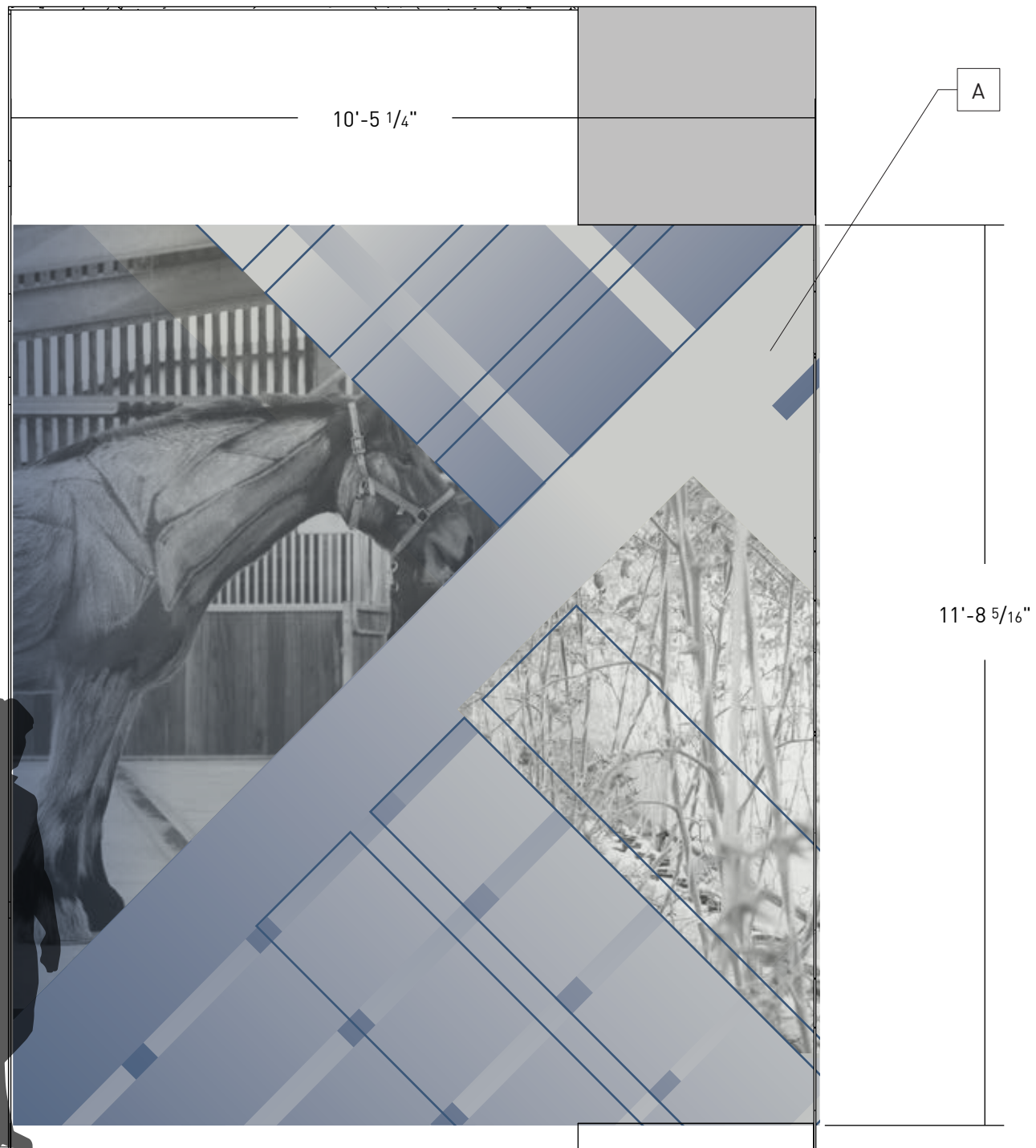

1 Elevation Graphic Activation
Scale: 1/2"=1'-0"

ELEMENT DESCRIPTION:

A
Digitally printed to DreamScape
Suede wallcovering

SAMPLE REQUESTED
2' x 2' Wallcovering



ELEVATION: C.9 Huddle Room Graphics *Floor Three*

SCALE: 1/2" = 1'0"



1 Elevation Huddle Room Graphic
Scale: 1/2"=1'-0"

ELEMENT DESCRIPTION:

A
Digitally printed to DreamScape
Suede wallcovering



ELEVATION: C.10 Huddle Room Graphics *Floor Three*

SCALE: 1/2" = 1'0"



① Elevation C.10 Huddle Room Graphics
Scale: 1/2"=1'-0"

ELEMENT DESCRIPTION:

A
Digitally printed to DreamScape
Suede wallcovering



ELEVATION: E.22 Window Vinyl, C.9 Donor Plaque *Floor Three*

SCALE: 3/8" = 1'0"

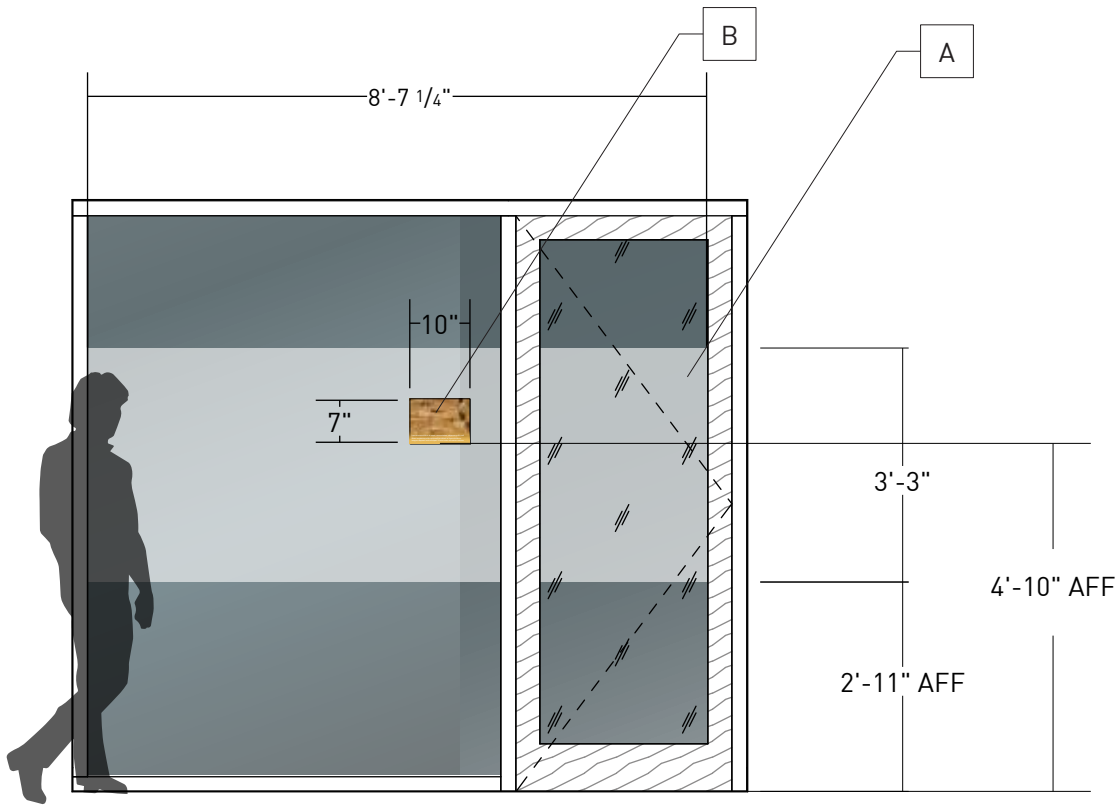

1 Elevation Window Vinyl
Scale: 3/8"=1'-0"

ELEMENT DESCRIPTION:

A
3M Dusted Crystal Vinyl, applied second surface

B
[QTY 1]
1/2" clear acrylic, printed first surface. Applied to glass with VHB tape, first surface

When sign is applied to glass, add 10" x 7" white vinyl second surface to hide adhesive



ELEVATION: E.23 Window Vinyl *Floor Three*

SCALE: 3/8" = 1'0"

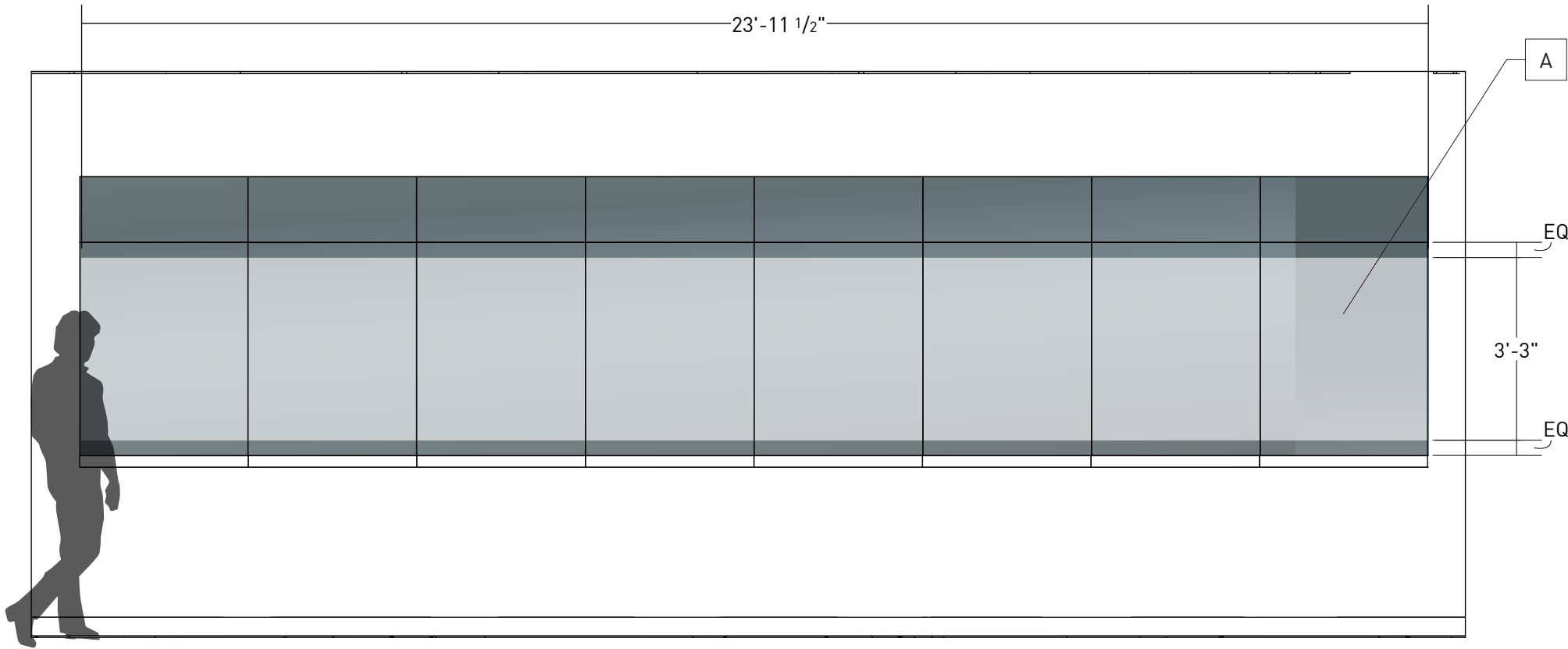

ELEMENT DESCRIPTION:

A
3M Dusted Crystal Vinyl, applied second surface

① Elevation Window Vinyl
Scale: 3/8"=1'-0"



ELEVATION: E.24 Window Vinyl *Floor Three*

SCALE: 3/8" = 1'0"

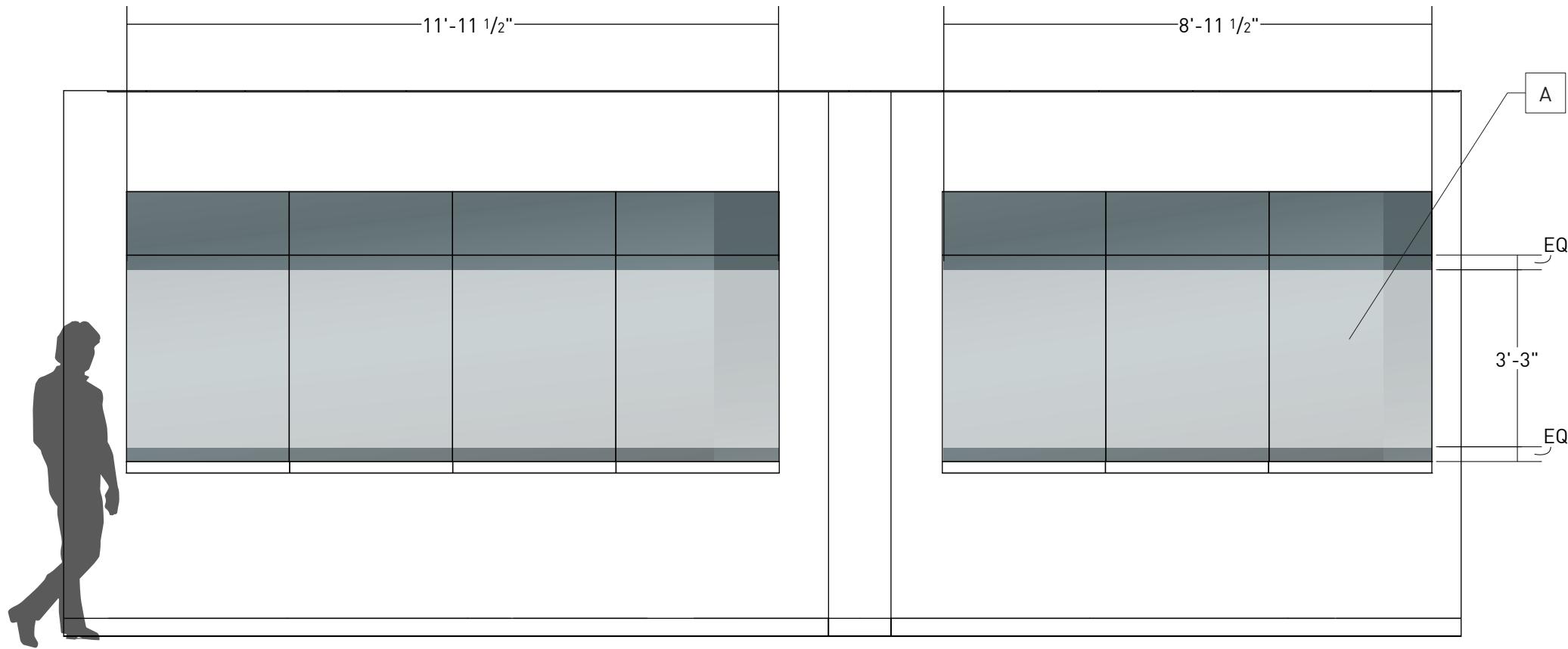

1 Elevation Window Vinyl
Scale: 3/8"=1'-0"

ELEMENT DESCRIPTION:

A
3M Dusted Crystal Vinyl, applied second surface



ELEVATION: E.25 Window Vinyl *Floor Three*

SCALE: 3/8" = 1'0"

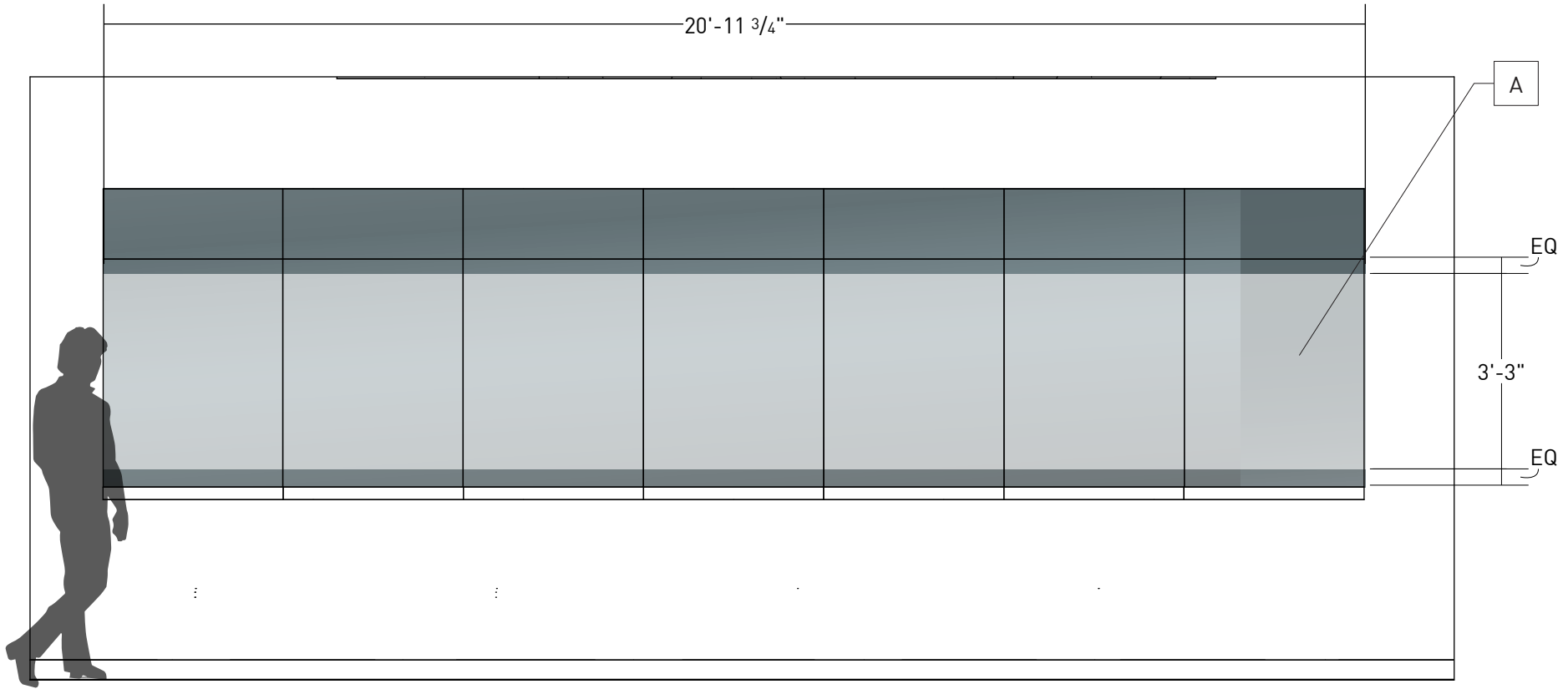

ELEMENT DESCRIPTION:

A
3M Dusted Crystal Vinyl, applied second surface

① Elevation Window Vinyl
Scale: 3/8"=1'-0"



ELEVATION: E.26 Window Vinyl *Floor Three*

SCALE: 3/8" = 1'0"

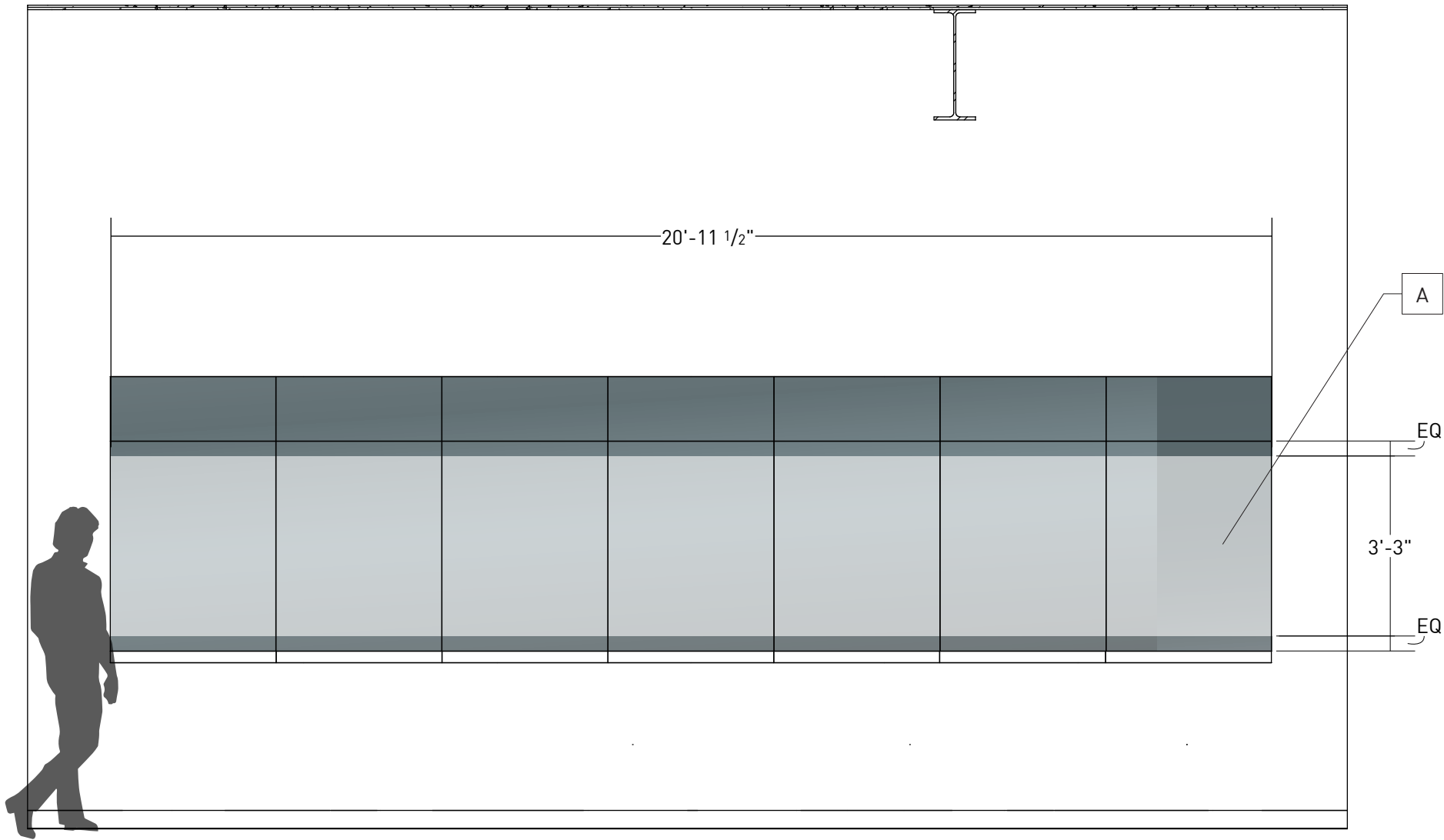

1 Elevation Window Vinyl
Scale: 3/8"=1'-0"

ELEMENT DESCRIPTION:

A
3M Dusted Crystal Vinyl, applied
second surface



ELEVATION: E.27 Window Vinyl *Floor Three*

SCALE: 3/8" = 1'-0"

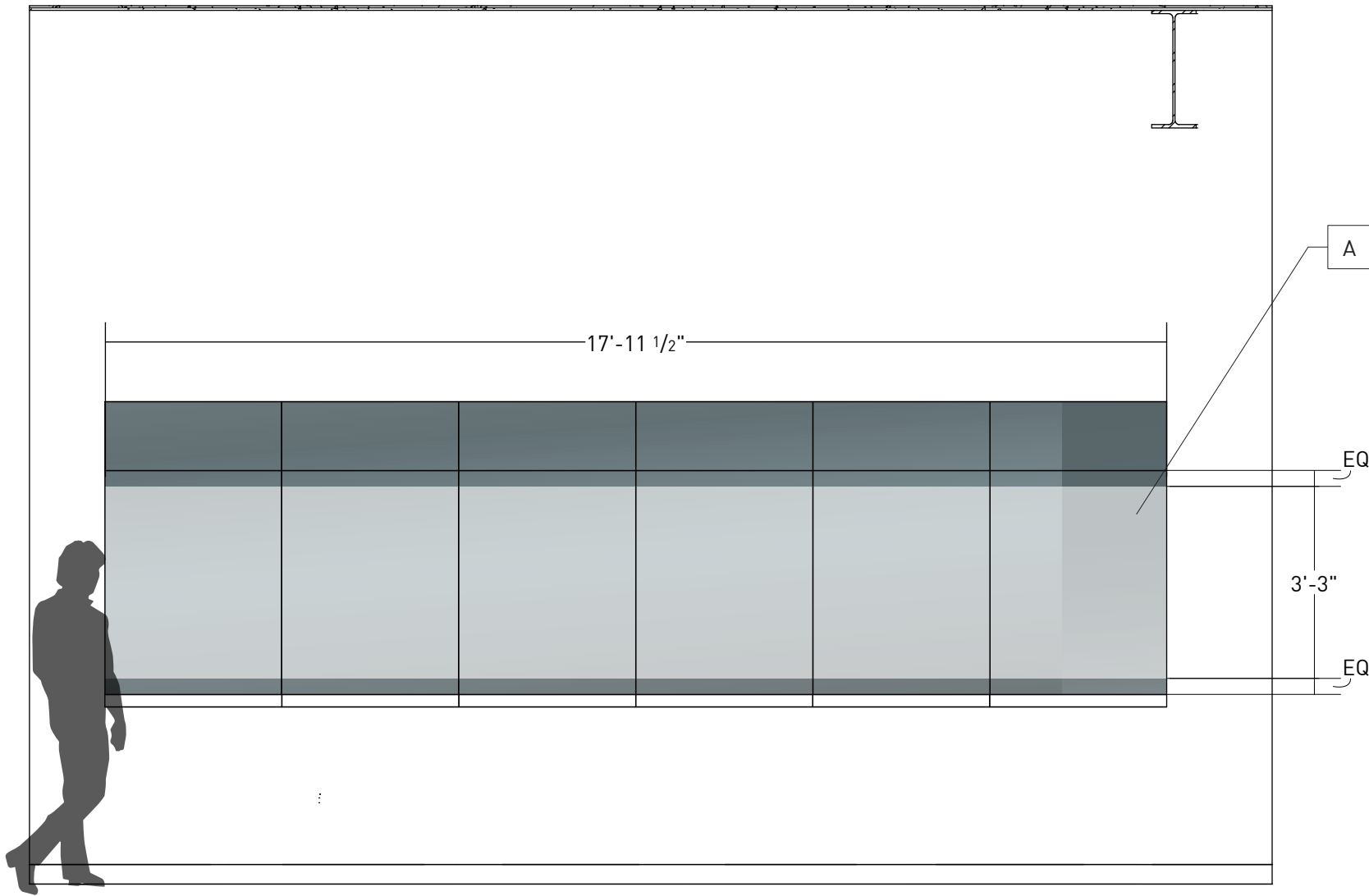

1 Elevation Window Vinyl
Scale: 3/8"=1'-0"

ELEMENT DESCRIPTION:

A
3M Dusted Crystal Vinyl, applied second surface



ELEVATION: E.28 Window Vinyl *Floor Three*

SCALE: 3/8" = 1'0"

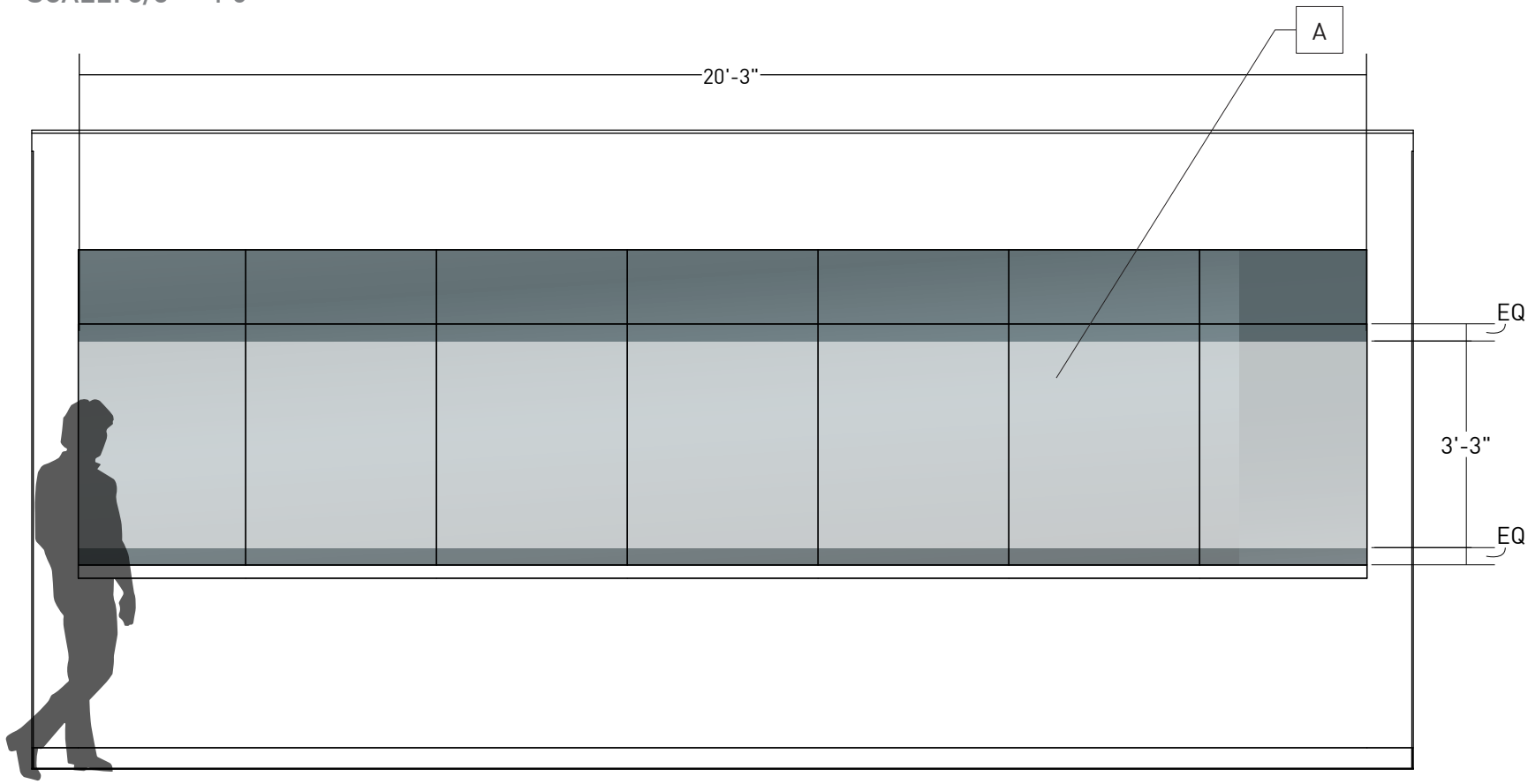

1 Elevation Window Vinyl
Scale: 3/8" = 1'-0"

ELEMENT DESCRIPTION:

A
3M Dusted Crystal Vinyl, applied
second surface



ELEVATION: E.29 Window Vinyl, **C.10** Donor Plaque *Floor Three*

SCALE: 3/8" = 1'0"

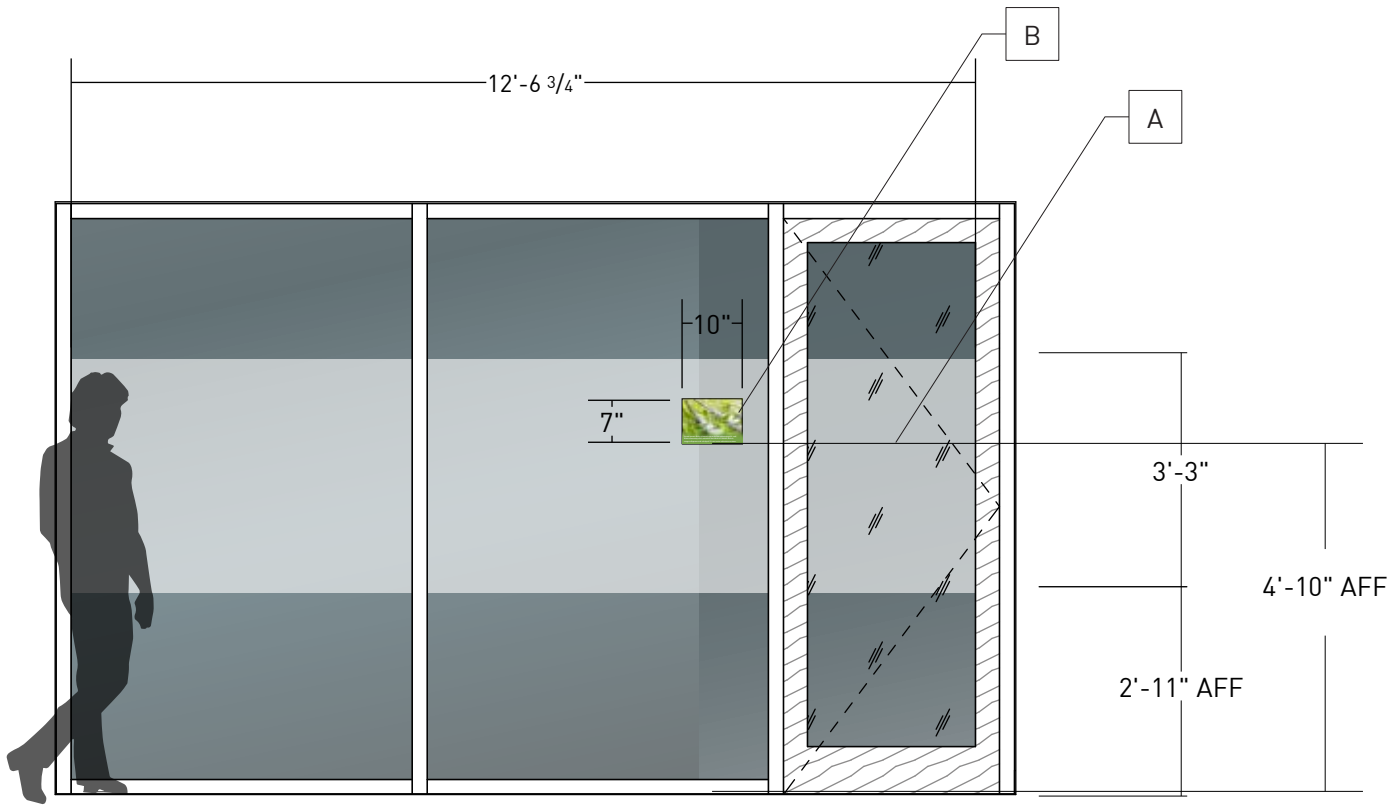

① Elevation **Window Vinyl**
Scale: 3/8"=1'-0"

ELEMENT DESCRIPTION:

A
3M Dusted Crystal Vinyl, applied second surface

B
[QTY 1]
1/2" clear acrylic, printed first surface. Applied to glass with VHB tape, first surface

When sign is applied to glass, add 10" x 7" white vinyl second surface to hide adhesive



ELEVATION: E.30 Window Vinyl *Floor Three*

SCALE: 3/8" = 1'0"

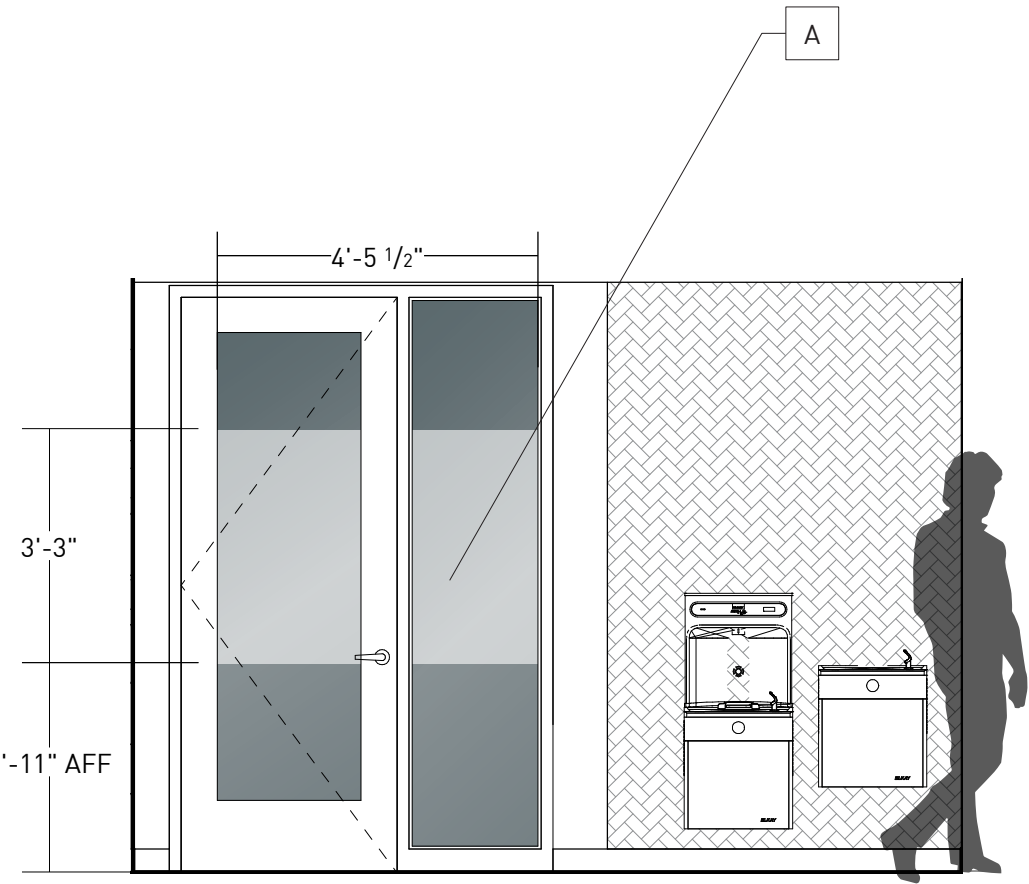

① Elevation **Window Vinyl**
Scale: 3/8" = 1'-0"

ELEMENT DESCRIPTION:

A
3M Dusted Crystal Vinyl, applied
second surface



FLOOR FOUR

ELEVATION: A.15 Entry Activation *Floor Four*

SCALE: 1/2" = 1'0"



ELEMENT DESCRIPTION:

A
Digitally printed to DreamScape Suede wallcovering

B
[QTY 3]
1/2" natural birch plywood, flat cut horizontally run. Direct print first surface, white ink underlay and color print. Z-clip to wall with tamper-proof fasteners. Sand to achieve smooth surface

C
MONITOR BY OTHERS

PAGE UPDATED
12.12.24



1 Elevation **Graphic Activation**
Scale: 1/2"=1'-0"

ELEVATION: A.14 Corridor Activation *Floor Four*

SCALE: 1/2" = 1'0"

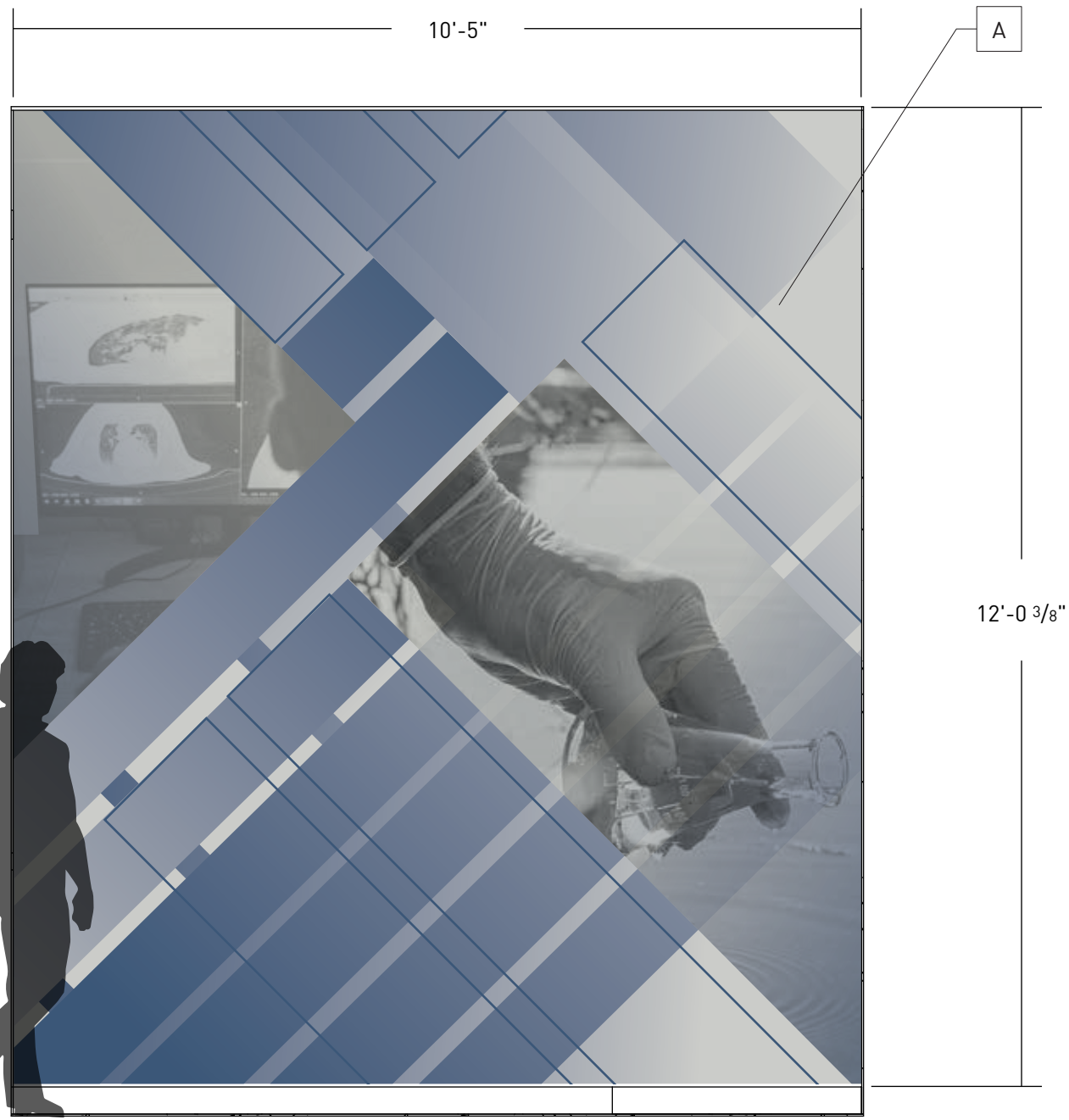

1 Elevation **Graphic Activation**
Scale: 1/2"=1'-0"

ELEMENT DESCRIPTION:

A
Digitally printed to DreamScape
Suede wallcovering



ELEVATION: A.13 Corridor Activation *Floor Four*

SCALE: 1/2" = 1'0"



ELEMENT DESCRIPTION:

A
Digitally printed to DreamScape
Suede wallcovering

1 Elevation **Graphic Activation**
Scale: 1/2"=1'-0"



ELEVATION: C.11 Classroom Graphic + Donor Plaque *Floor Four*

SCALE: 1/2" = 1'0"

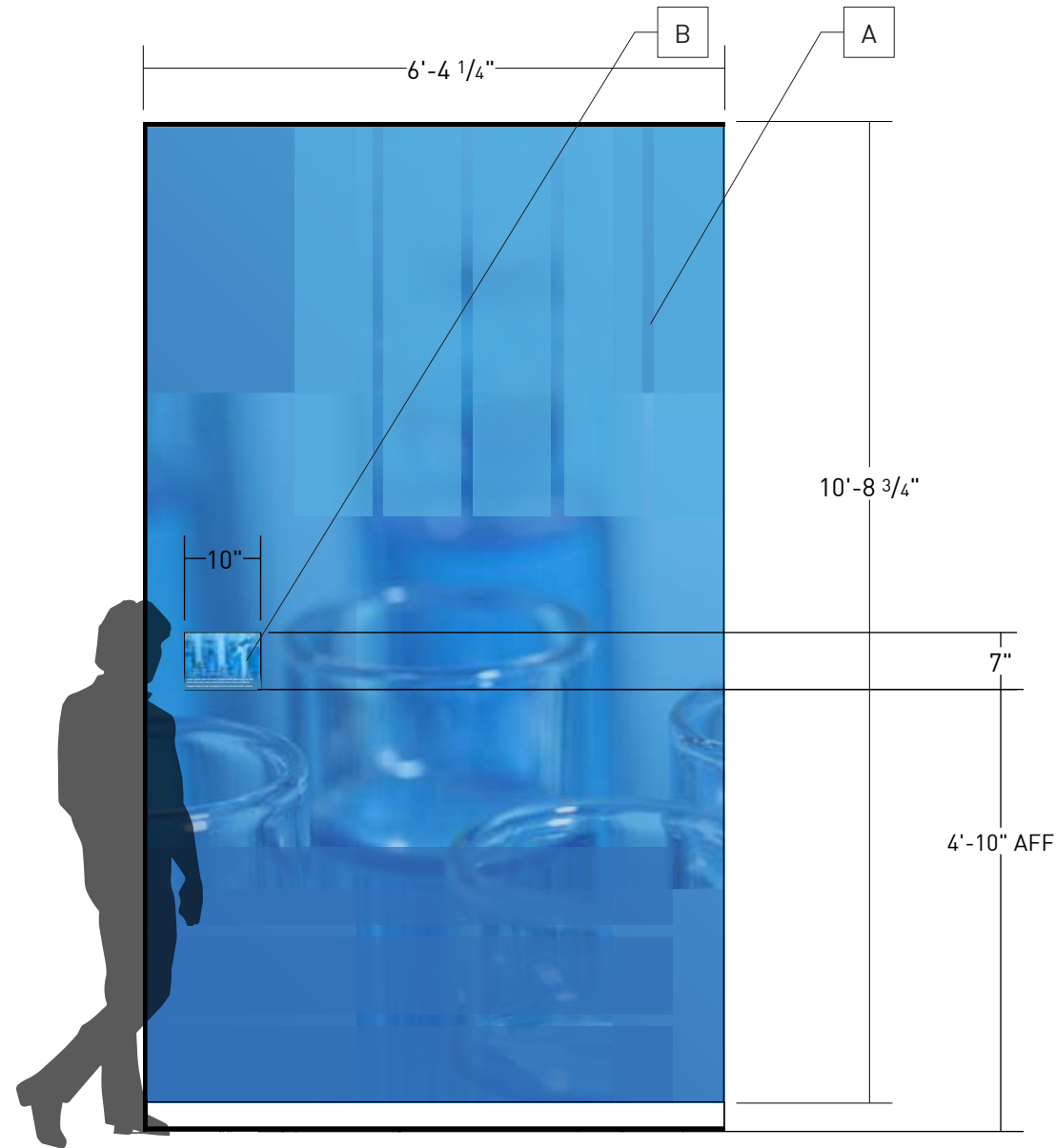

1 Elevation Classroom Graphic

Scale: 1/2"=1'-0"

ELEMENT DESCRIPTION:

A
Digitally printed to DreamScape Suede wallcovering

B
[QTY 1]
1/2" clear acrylic, printed first surface. Pin mounted to wall with silicone.

When sign is applied to glass, add 10" x 7" white vinyl second surface to hide adhesive

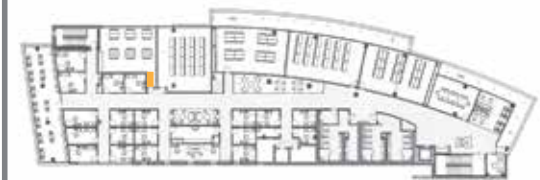

ELEVATION: E.40 Window Vinyl *Floor Four*

SCALE: 3/8" = 1'0"

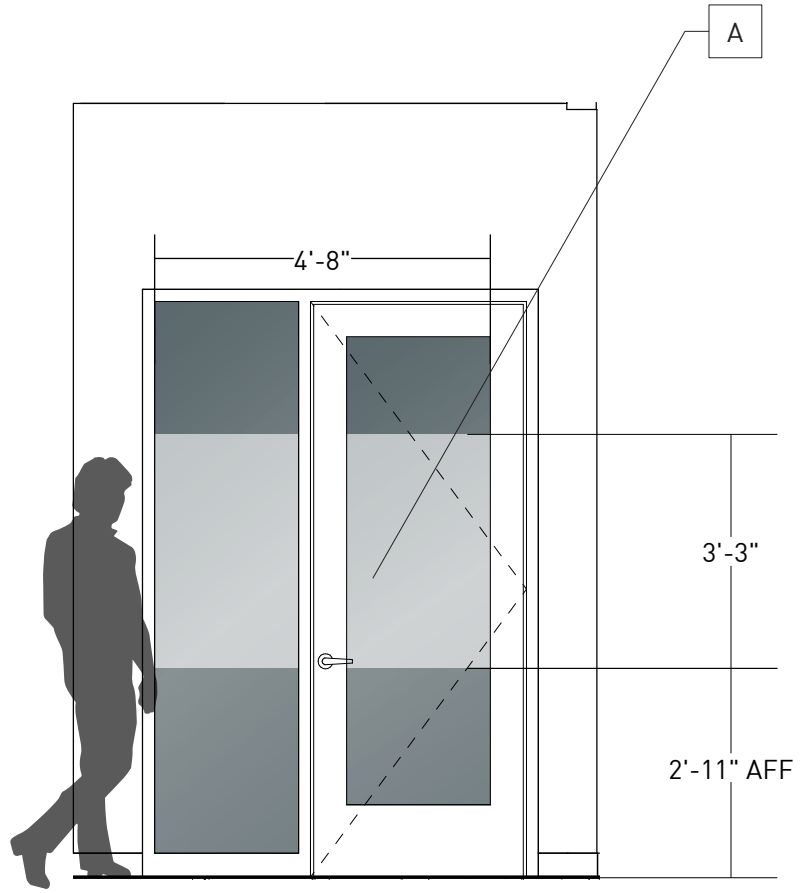

① Elevation Window Vinyl
Scale: 3/8" = 1'-0"

ELEMENT DESCRIPTION:

A
3M Dusted Crystal Vinyl, applied
second surface

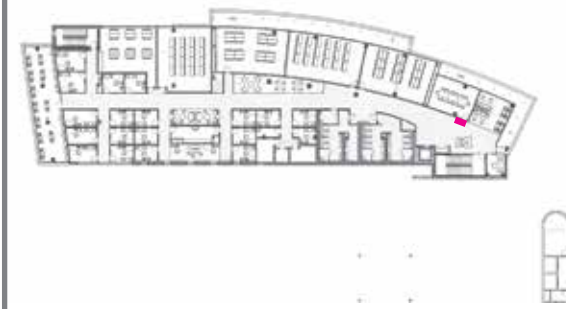

ELEVATION: E.41 Window Vinyl *Floor Four*

SCALE: 1/4" = 1'0"

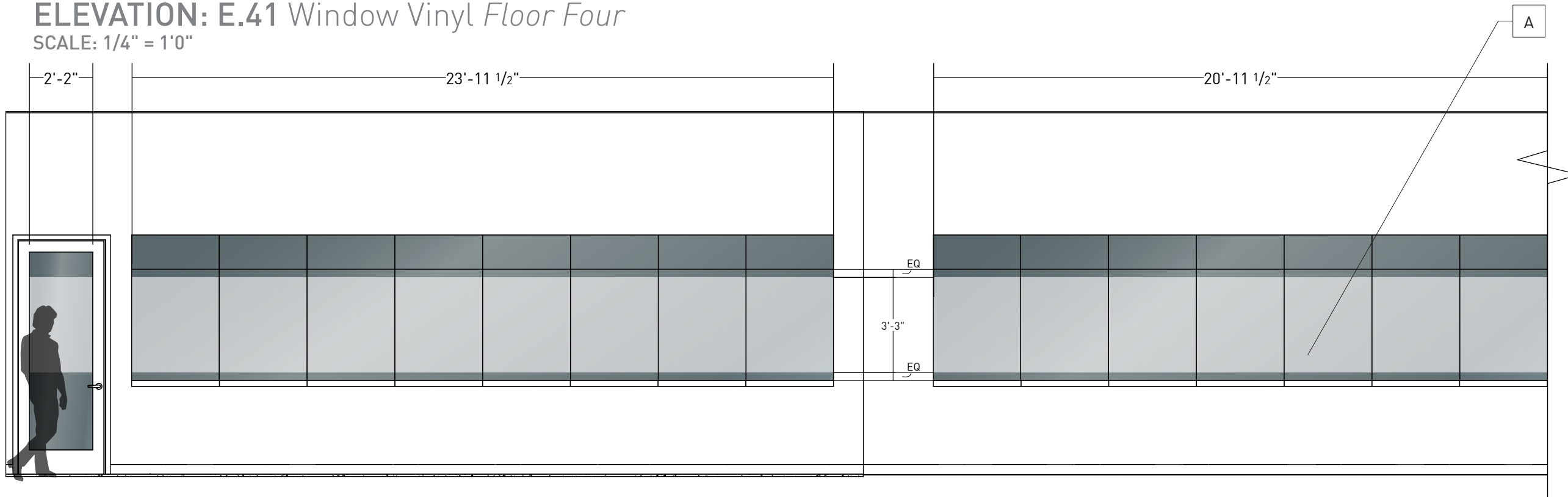

1 Elevation Window Vinyl
Scale: 1/4"=1'-0"

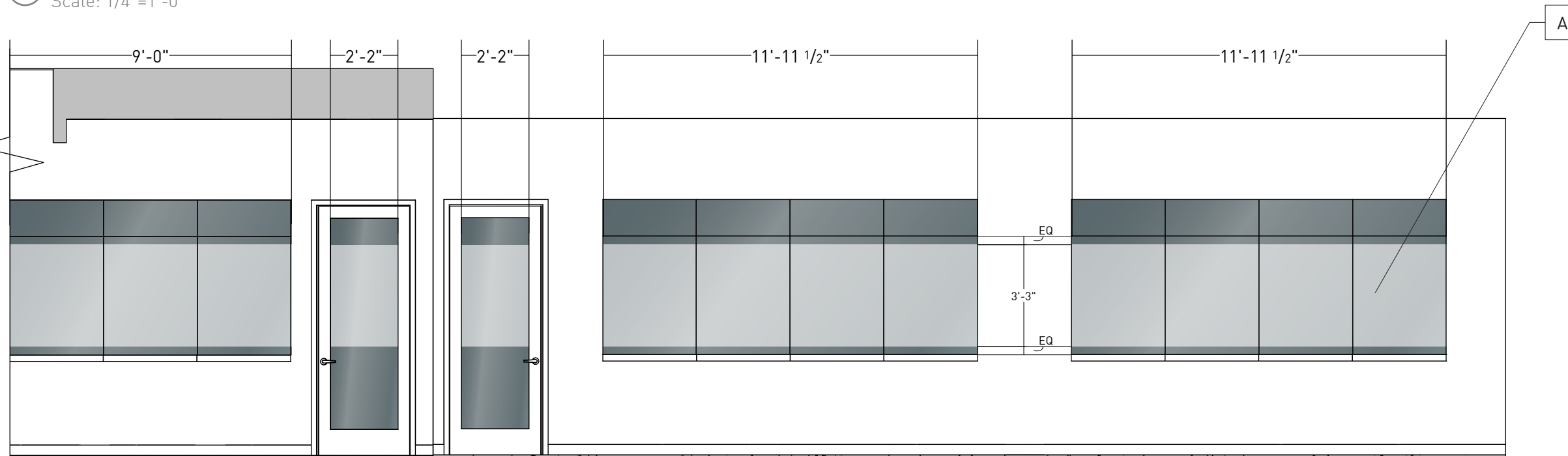

2 Elevation Window Vinyl
Scale: 1/4"=1'-0"

ELEMENT DESCRIPTION:

A
3M Dusted Crystal Vinyl, applied second surface



ELEVATION: E.49 Window Vinyl Floor Four

SCALE: 3/8" = 1'0"

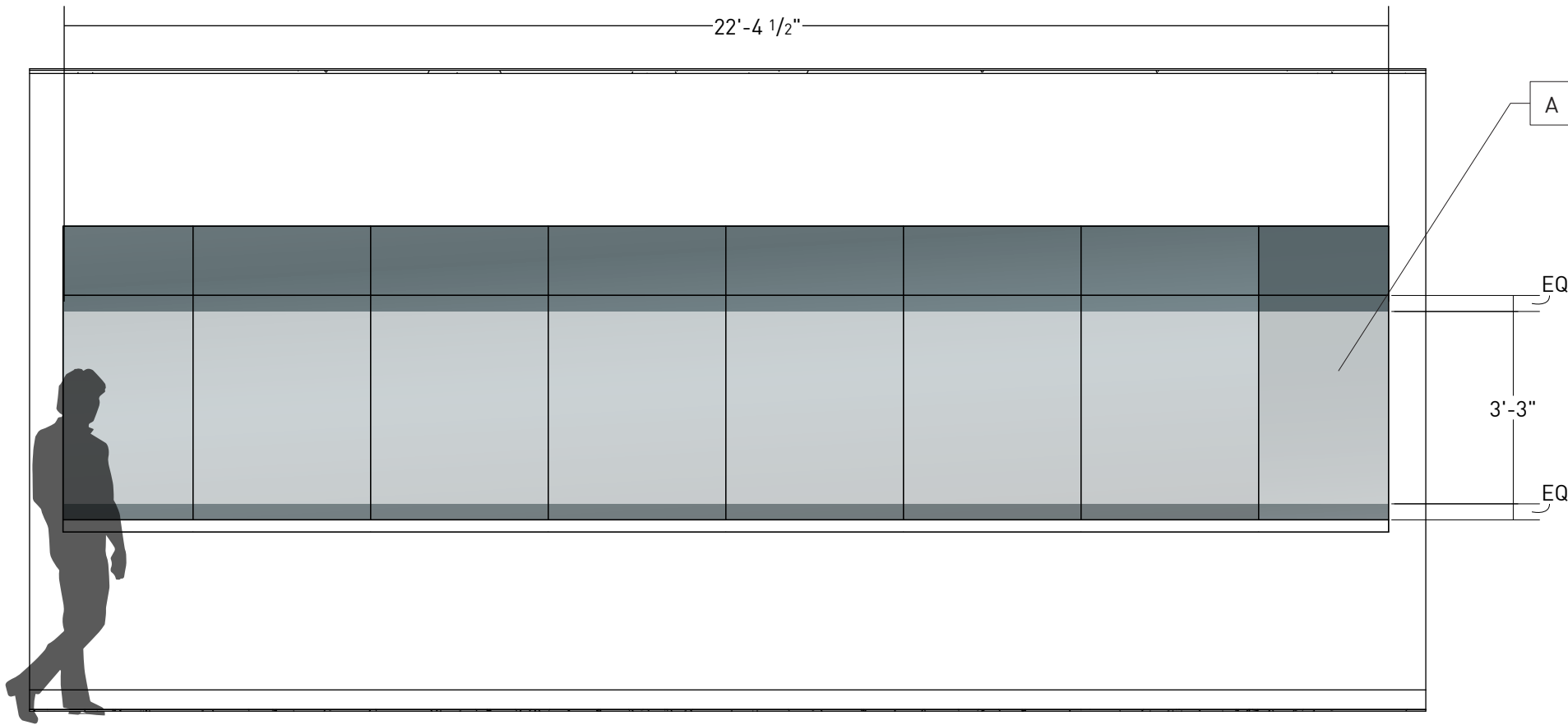

1 Elevation Window Vinyl
Scale: 3/8"=1'-0"

ELEMENT DESCRIPTION:

A
3M Dusted Crystal Vinyl, applied second surface



ELEVATION: E.43 Window Vinyl *Floor Four*

SCALE: 3/8" = 1'0"

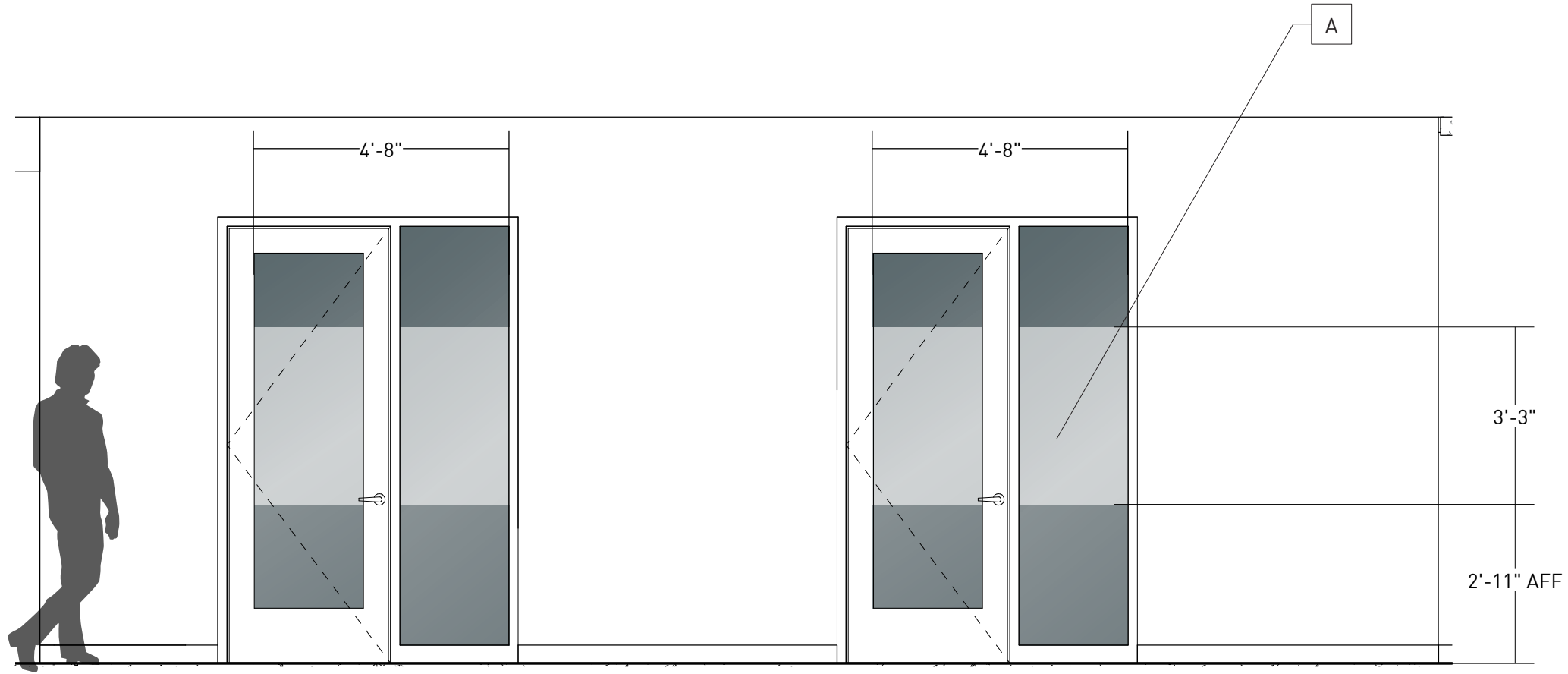

1 Elevation Window Vinyl
Scale: 3/8"=1'-0"

ELEMENT DESCRIPTION:

A
3M Dusted Crystal Vinyl, applied second surface



ELEVATION: E.44 Window Vinyl Floor Four

SCALE: 3/8" = 1'0"

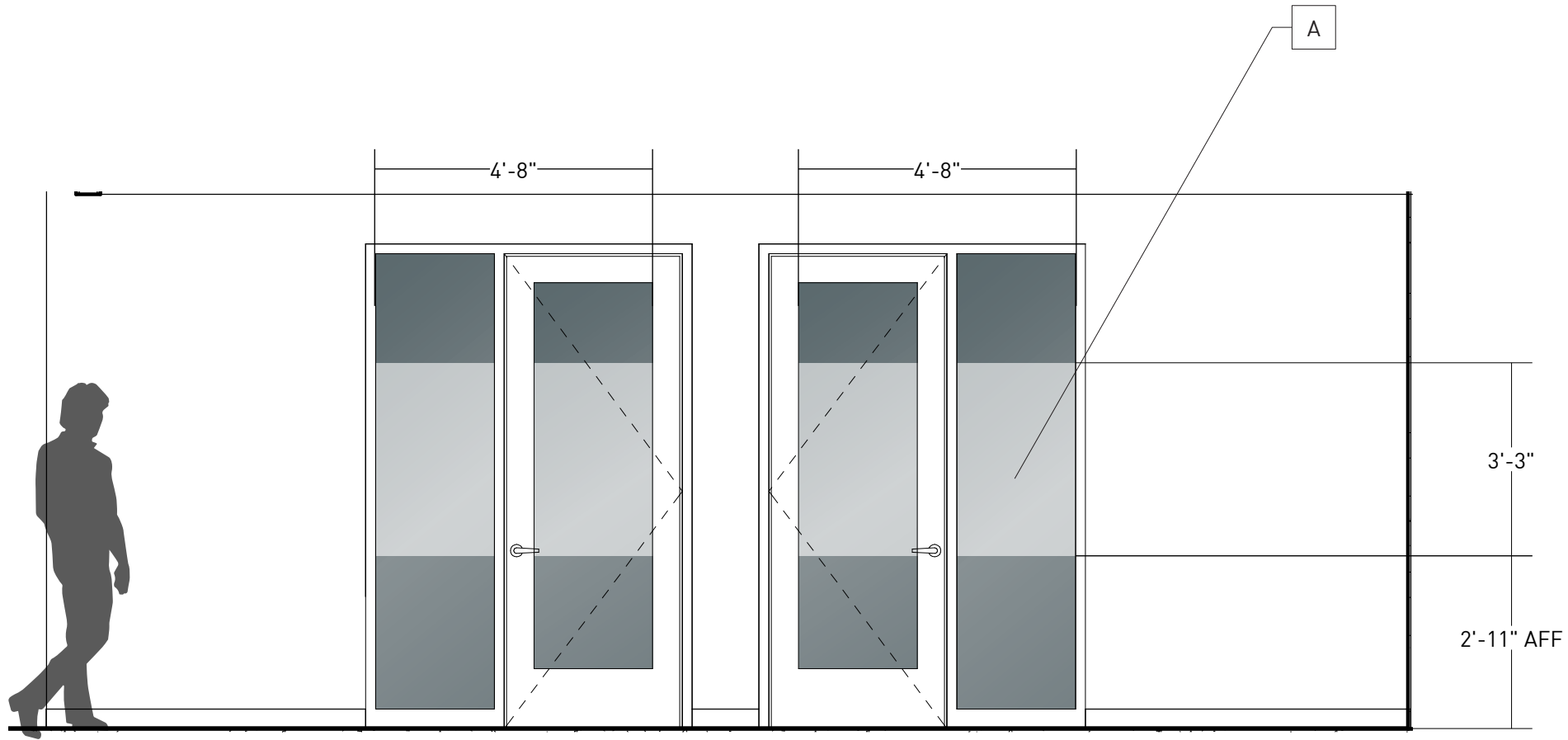

1 Elevation Window Vinyl
Scale: 3/8"=1'-0"

ELEMENT DESCRIPTION:

A
3M Dusted Crystal Vinyl, applied second surface

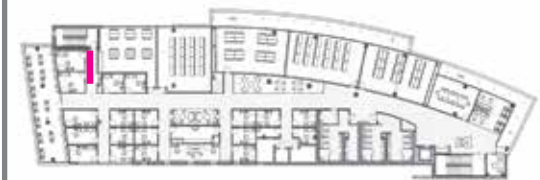

ELEVATION: E.45 Window Vinyl Floor Four

SCALE: 3/8" = 1'0"

ELEMENT DESCRIPTION:

A
3M Dusted Crystal Vinyl, applied second surface

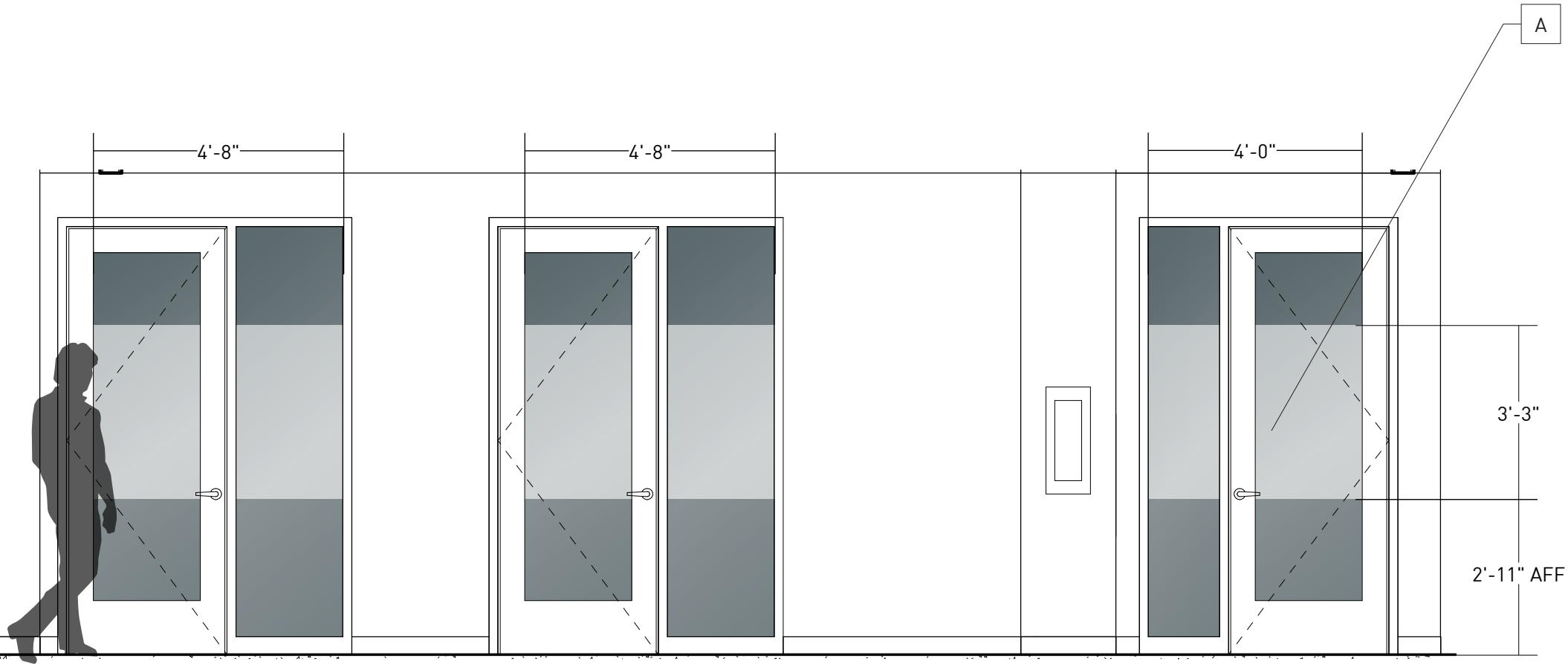

1 Elevation Window Vinyl
Scale: 3/8"=1'-0"

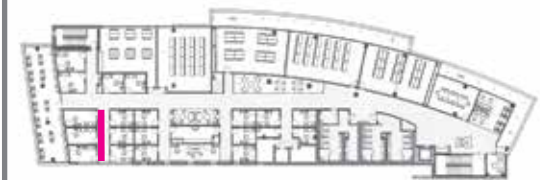

ELEVATION: E.46 Window Vinyl Floor Four

SCALE: 3/8" = 1'0"

ELEMENT DESCRIPTION:

A
3M Dusted Crystal Vinyl, applied second surface

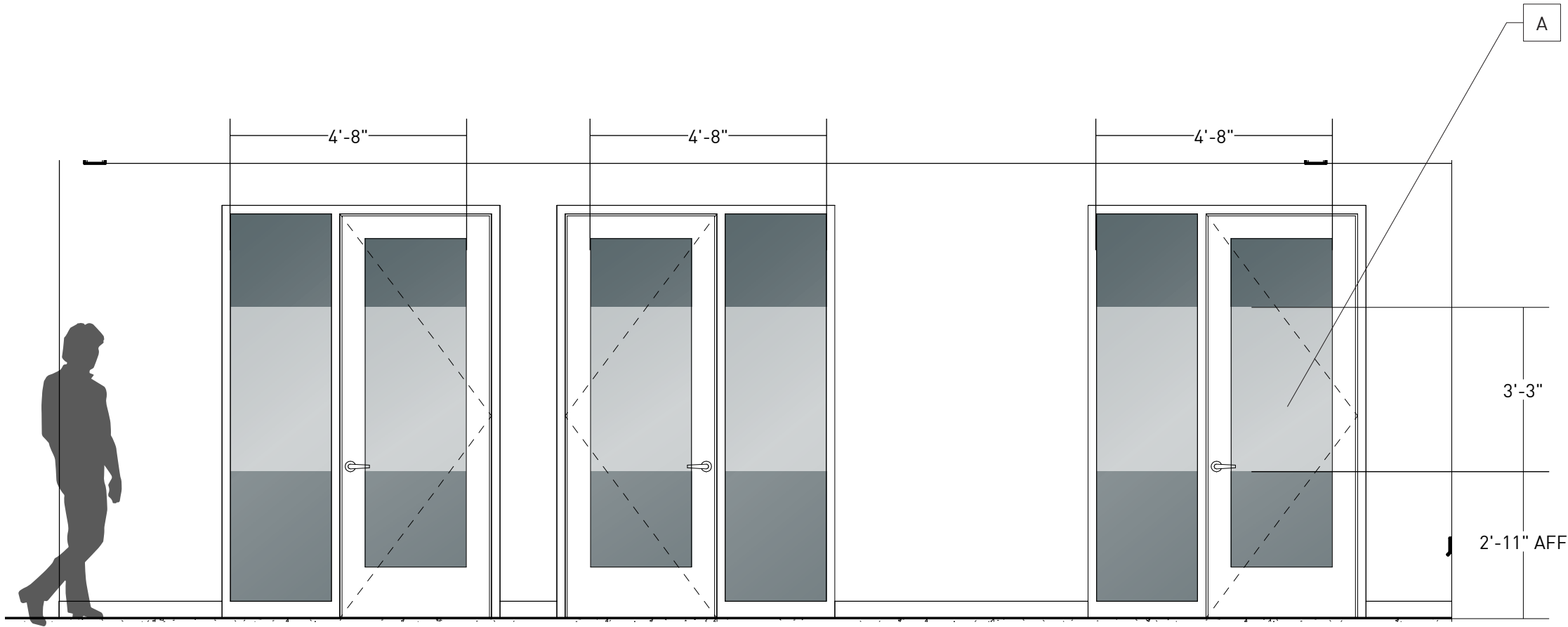

1 Elevation Window Vinyl
Scale: 3/8"=1'-0"



ELEVATION: E.47 Window Vinyl Floor Four

SCALE: 3/8" = 1'0"

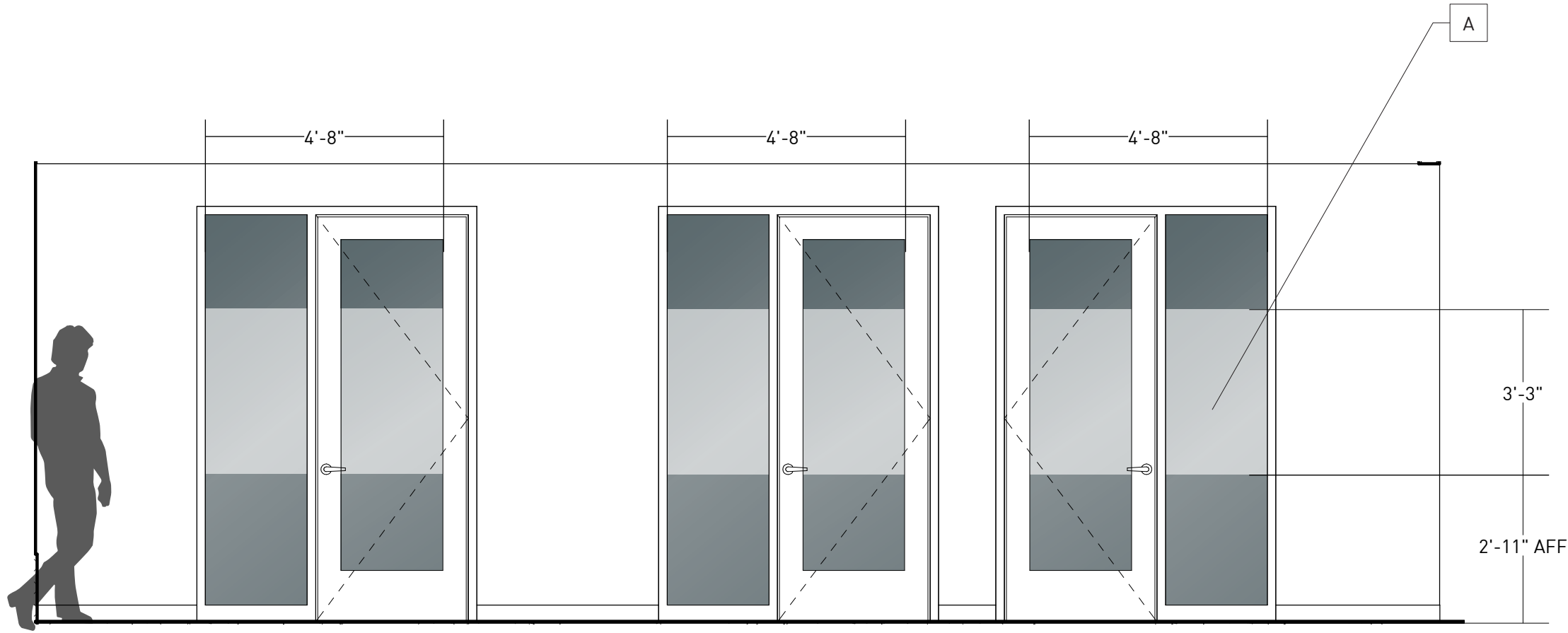

1 Elevation Window Vinyl
Scale: 3/8"=1'-0"

ELEMENT DESCRIPTION:

A
3M Dusted Crystal Vinyl, applied second surface

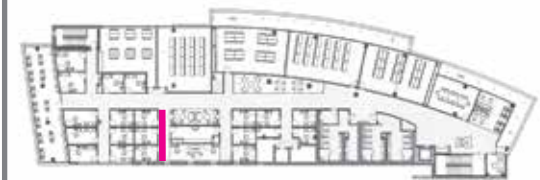

ALL FLOORS

ELEVATION: D.1 Stair Activation

SCALE: 1/8" = 1'0"

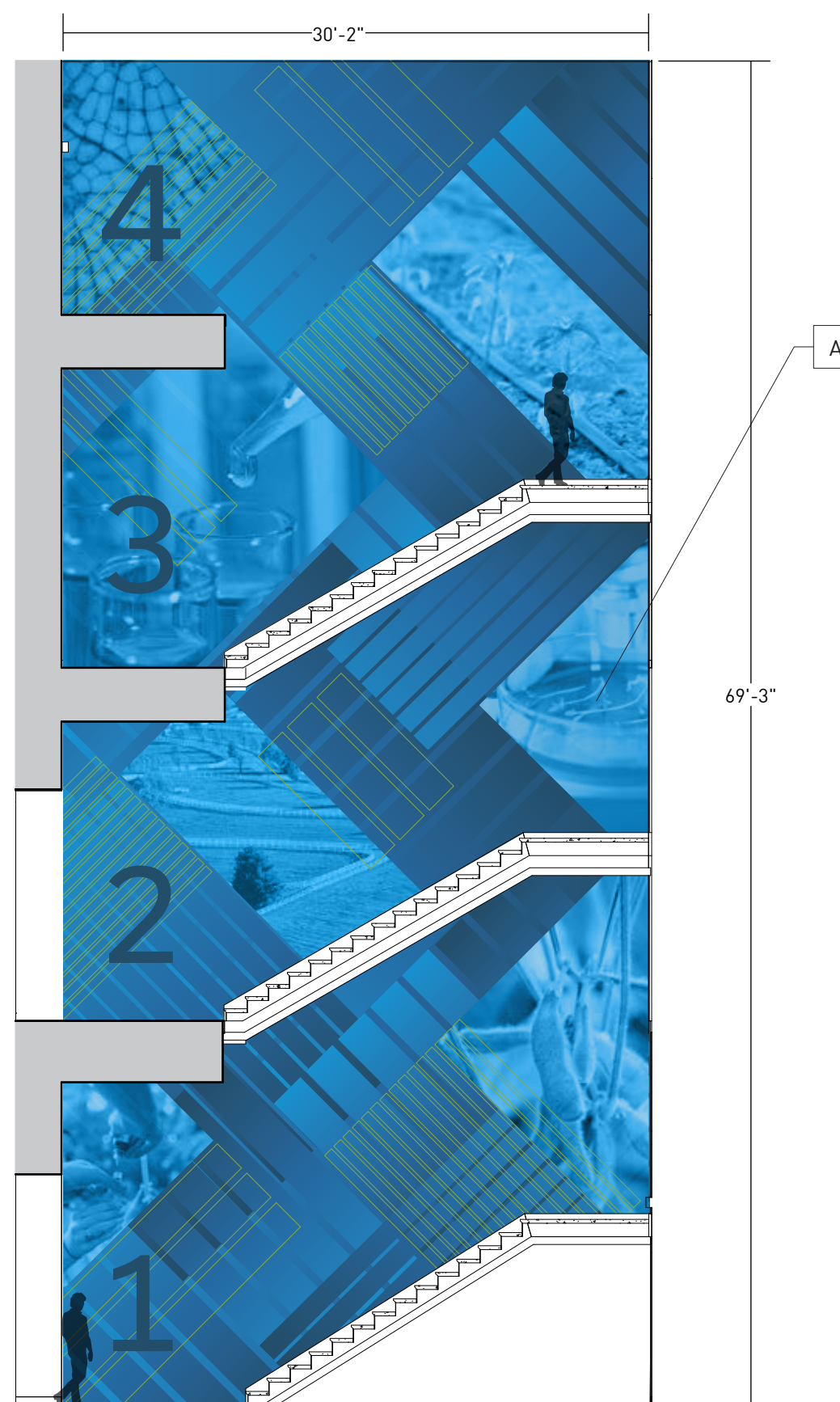

1 Elevation Stair Activation
Scale: 1/8"=1'-0"

ELEMENT DESCRIPTION:

A
Dreamscapes Suede or equivalent product that meets Class A flame spread index in accordance with ASTM E84 or UL723

SAMPLE REQUESTED
5' x 2' Wallcovering

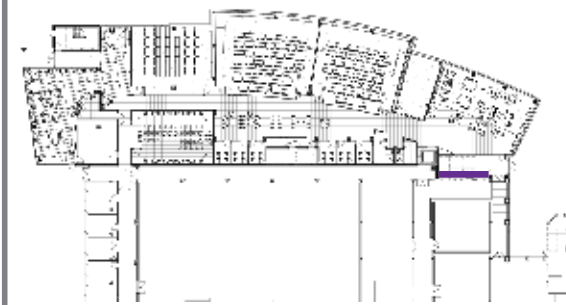

ELEVATION: D.2 Stair Activation

SCALE: 3/32" = 1'-0", 1/4" = 1'-0"

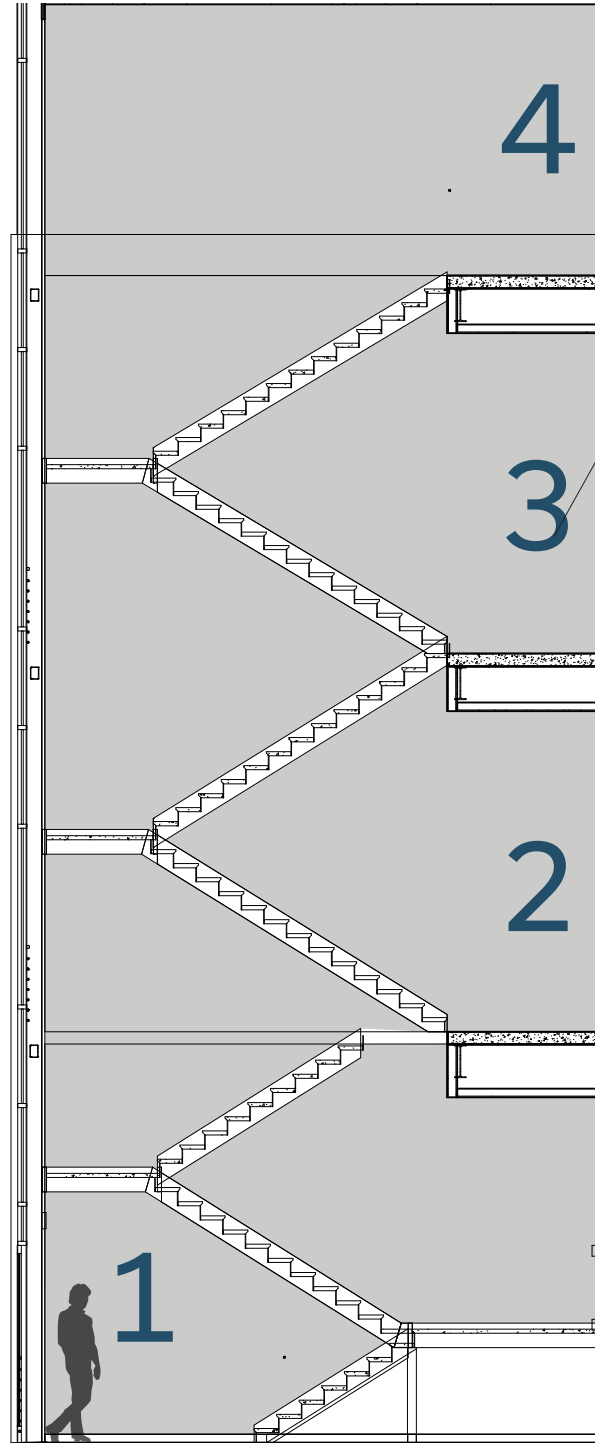

1 Elevation Stair Activation
Scale: 3/32"=1'-0"

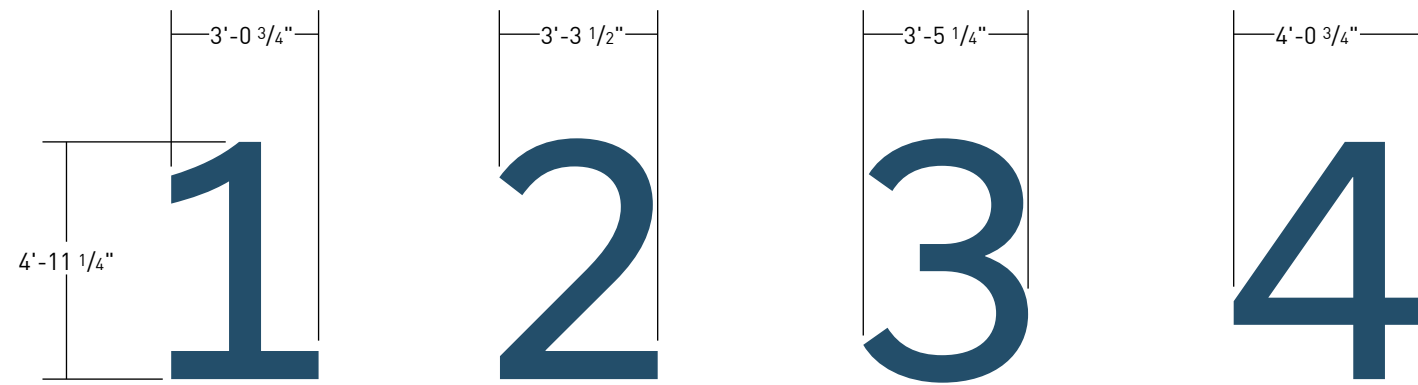

2 Elevation Element A Detail
Scale: 1/4"=1'-0"

ELEMENT DESCRIPTION:

A
Digitally printed to white vinyl or equivalent product that meets Class A flame spread index in accordance with ASTM E84 or UL723

Cut and weeded

SAMPLE REQUESTED
2' x 2' Vinyl

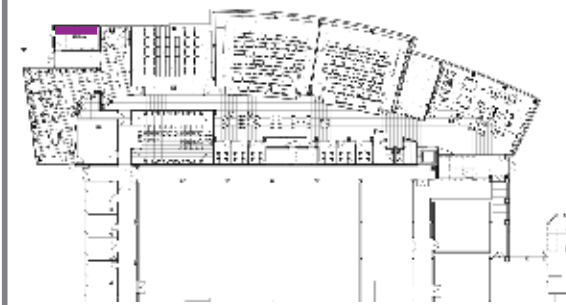

ELEVATION: E.13 & E.31 Window Vinyl *Floor Two & Three*

SCALE: 1/4" = 1'-0"

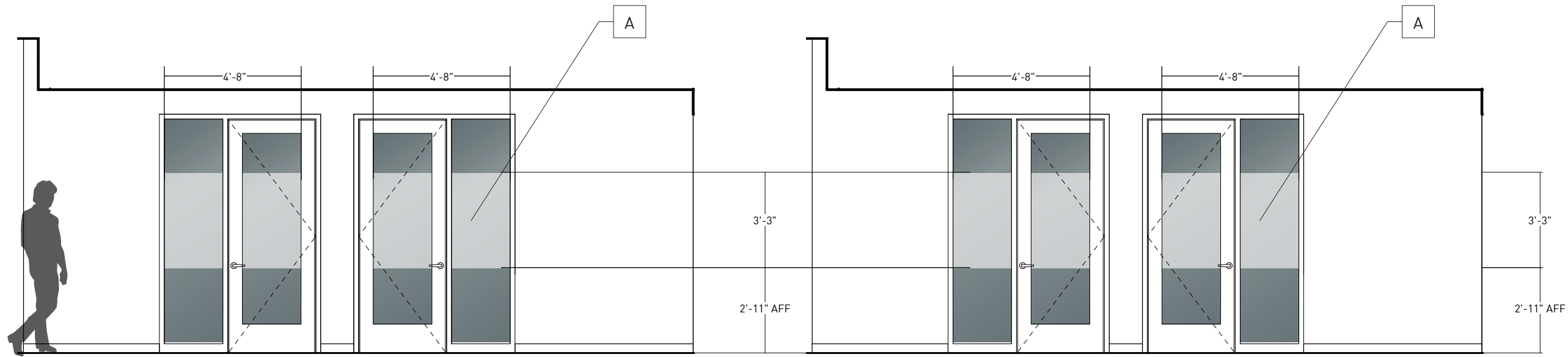

1 Elevation E.13 Window Vinyl
Scale: 1/4"=1'-0"

2 Elevation E.31 Window Vinyl
Scale: 1/4"=1'-0"

ELEMENT DESCRIPTION:

A
3M Dusted Crystal Vinyl, applied second surface

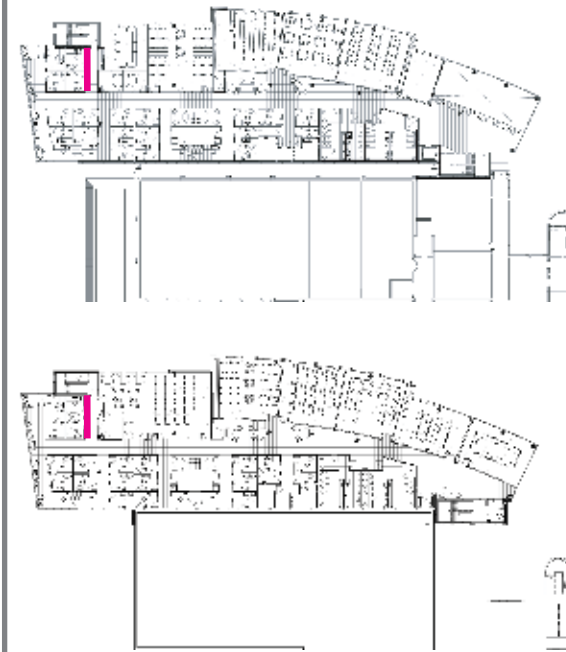

ELEVATION: E.14 & E.32 Window Vinyl Floor Two & Three

SCALE: 3/8" = 1'0"

ELEMENT DESCRIPTION:

A
3M Dusted Crystal Vinyl, applied second surface

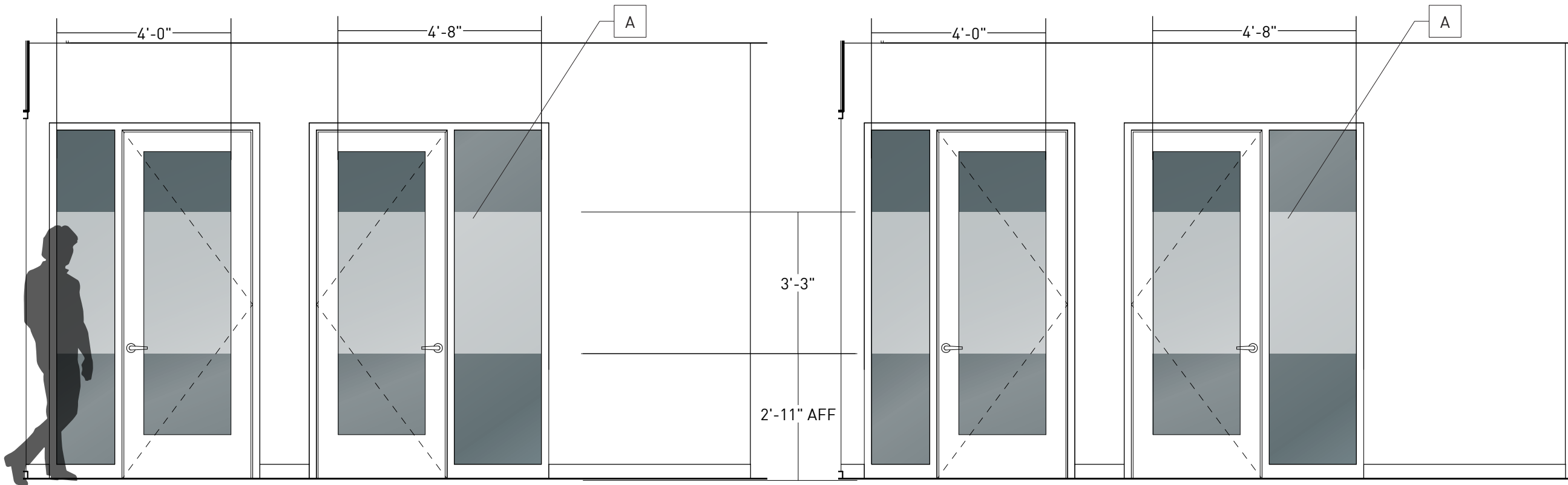

1 Elevation E.14 Window Vinyl
Scale: 3/8"=1'-0"

2 Elevation E.32 Window Vinyl
Scale: 3/8"=1'-0"

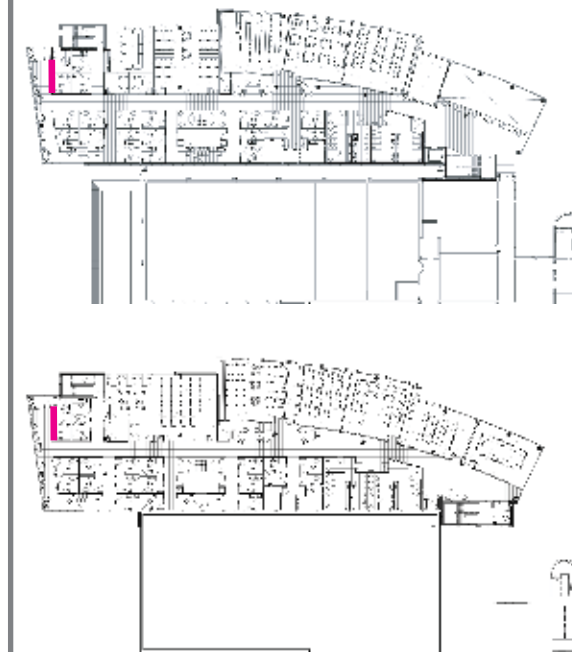

ELEVATION: E.15 & E.33 Window Vinyl Floor Two & Three

SCALE: 1/4" = 1'-0"

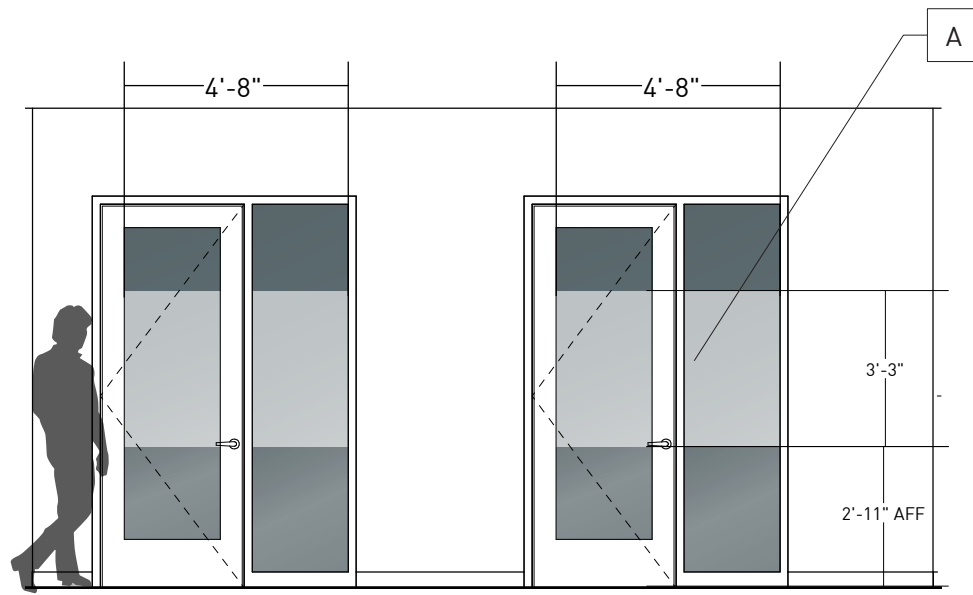

1 Elevation E.15 Window Vinyl
Scale: 1/4"=1'-0"

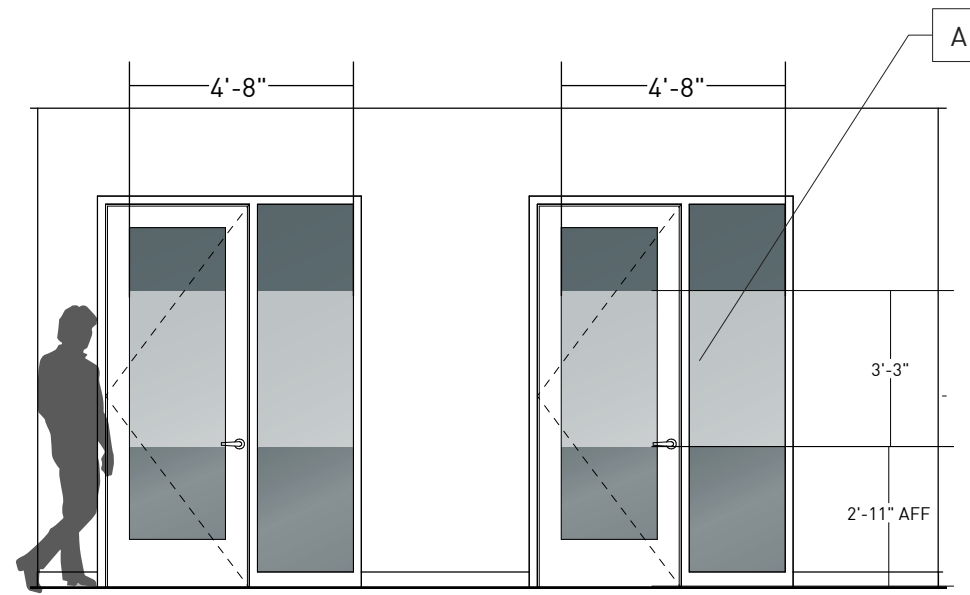

2 Elevation E.33 Window Vinyl
Scale: 1/4"=1'-0"

ELEMENT DESCRIPTION:

A
3M Dusted Crystal Vinyl, applied
second surface

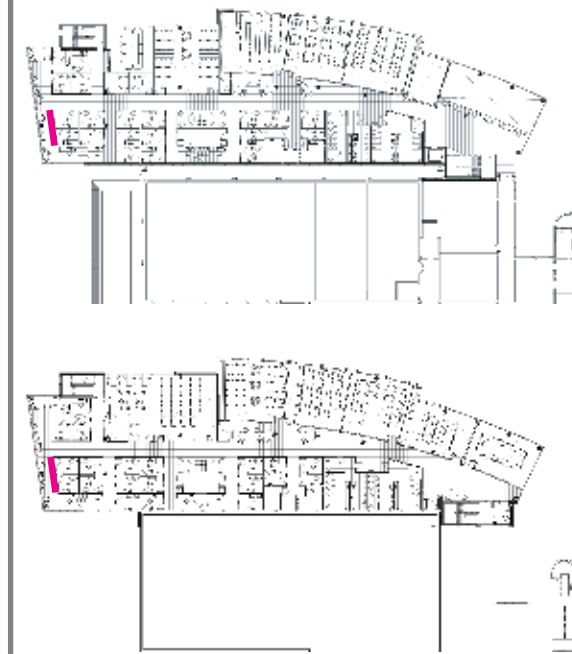

ELEVATION: E.16 & E.34 Window Vinyl Floor Two & Three

SCALE: 1/4" = 1'-0"

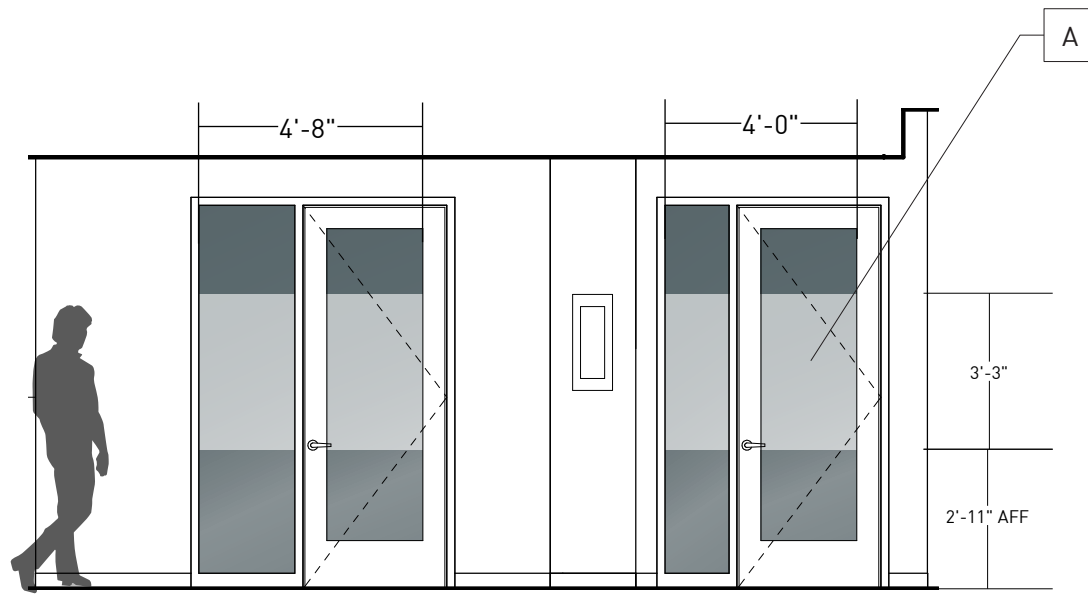

1 Elevation E.16 Window Vinyl
Scale: 1/4"=1'-0"

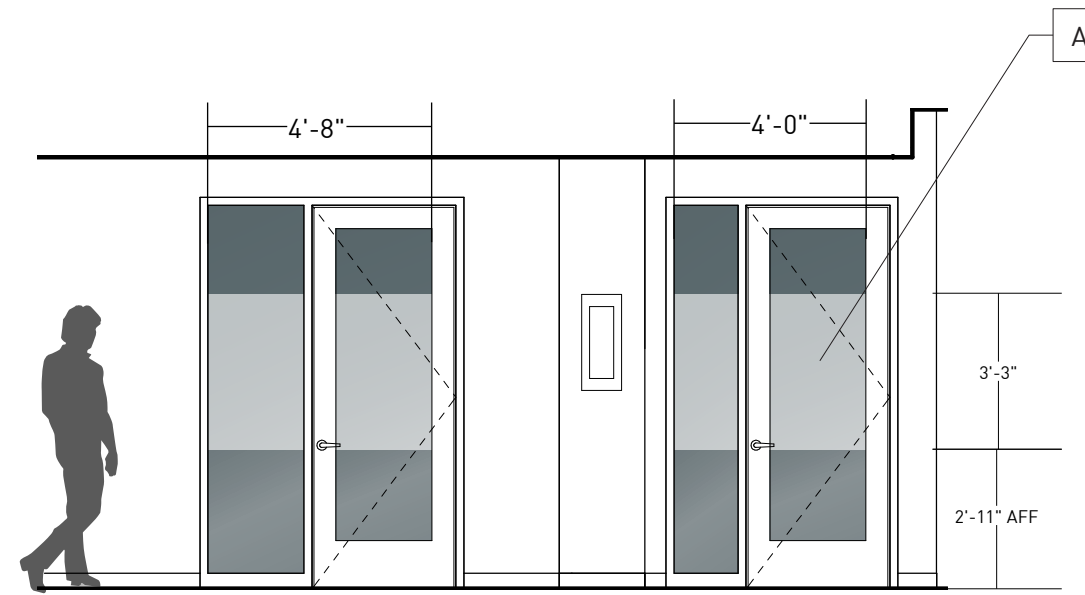

2 Elevation E.34 Window Vinyl
Scale: 1/4"=1'-0"

ELEMENT DESCRIPTION:

A
3M Dusted Crystal Vinyl, applied second surface

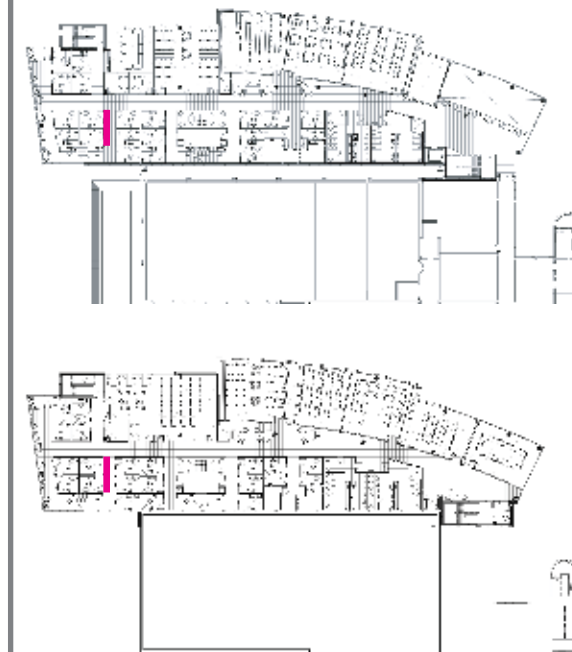

ELEVATION: E.17,E.19,E.35,E.37 & E.48 Window Vinyl *Floor Two, Three & Four*

SCALE: 3/16" = 1'-0"

ELEMENT DESCRIPTION:

A
3M Dusted Crystal Vinyl, applied second surface

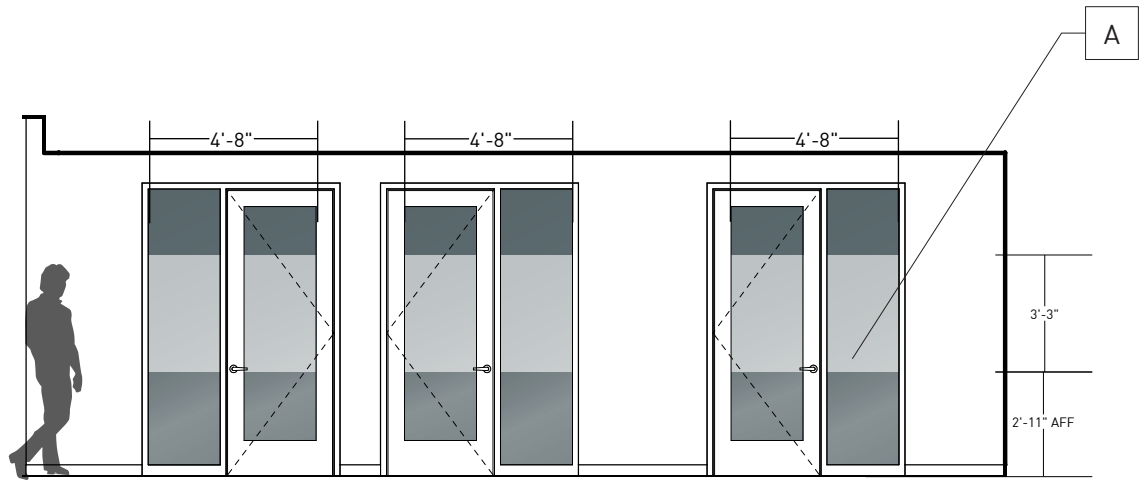

1 Elevation E.17 Window Vinyl
Scale: 3/16"=1'-0"

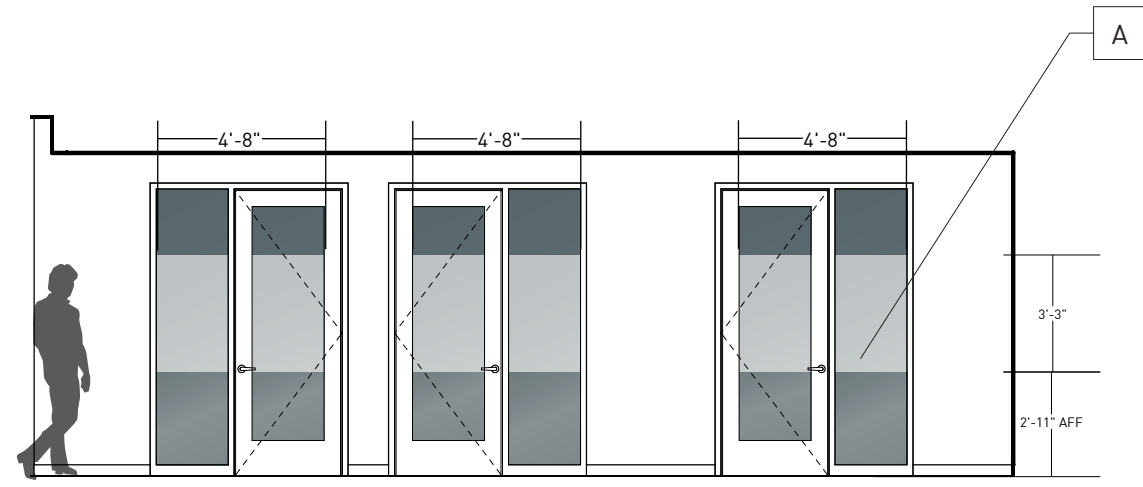

2 Elevation E.19 Window Vinyl
Scale: 3/16"=1'-0"

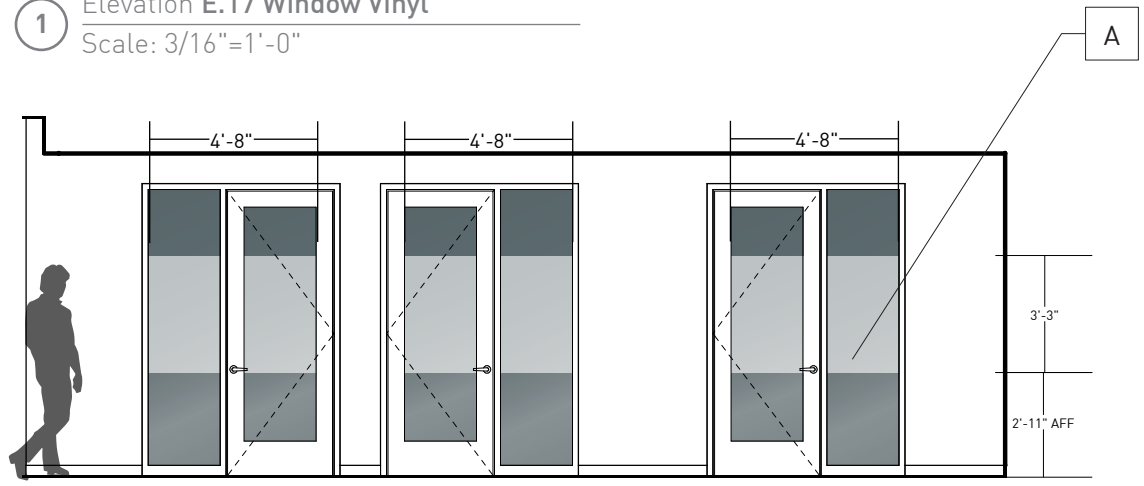

3 Elevation E.35 Window Vinyl
Scale: 3/16"=1'-0"

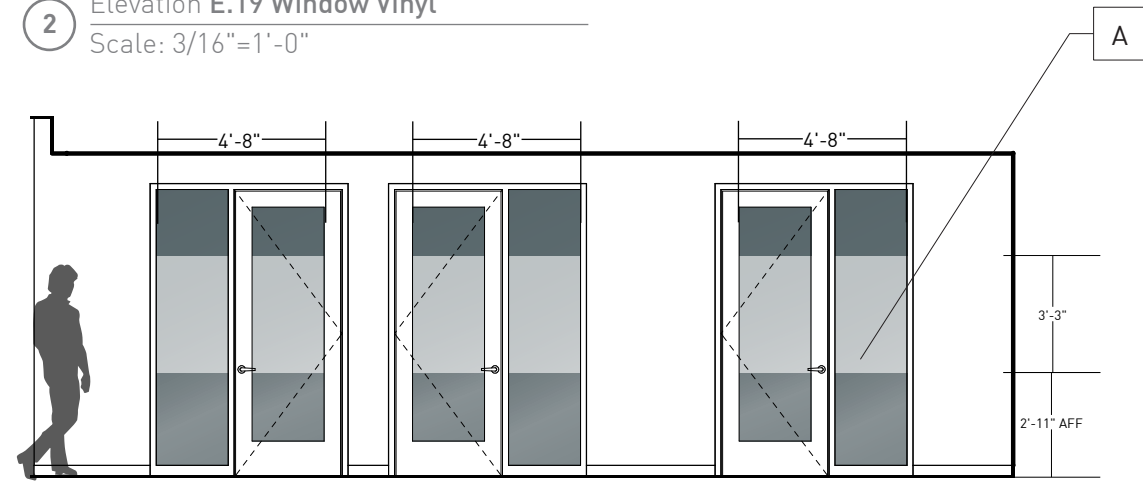

4 Elevation E.37 Window Vinyl
Scale: 3/16"=1'-0"

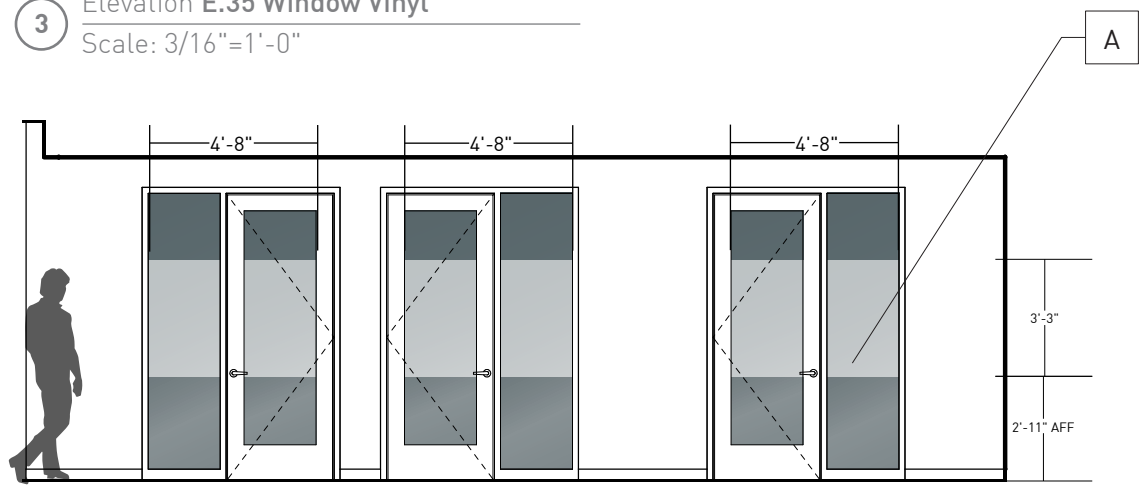

5 Elevation E.48 Window Vinyl
Scale: 3/16"=1'-0"

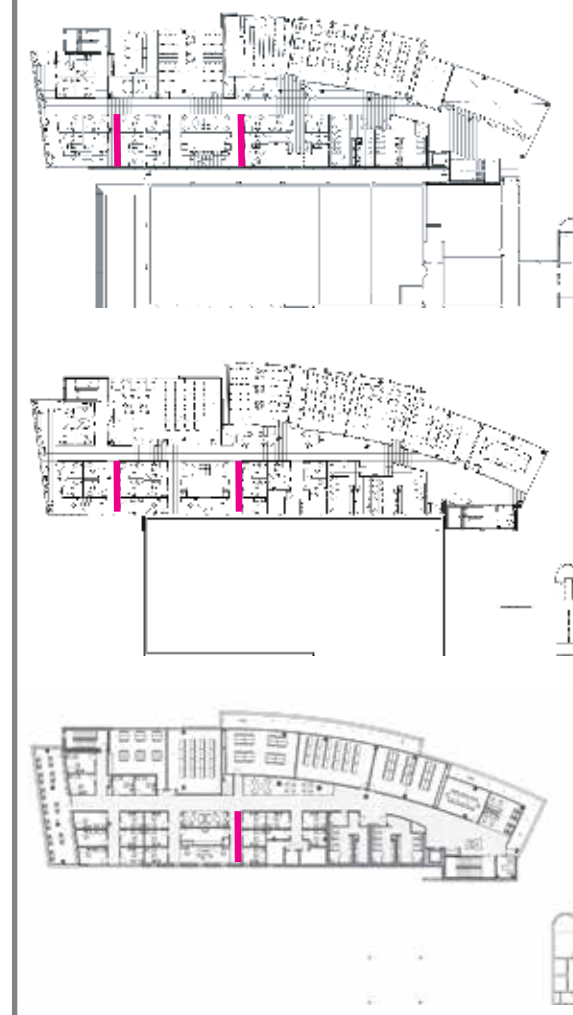

ELEVATION: E.18 & E.36 Window Vinyl Floor Two & Three

SCALE: 1/4" = 1'0"

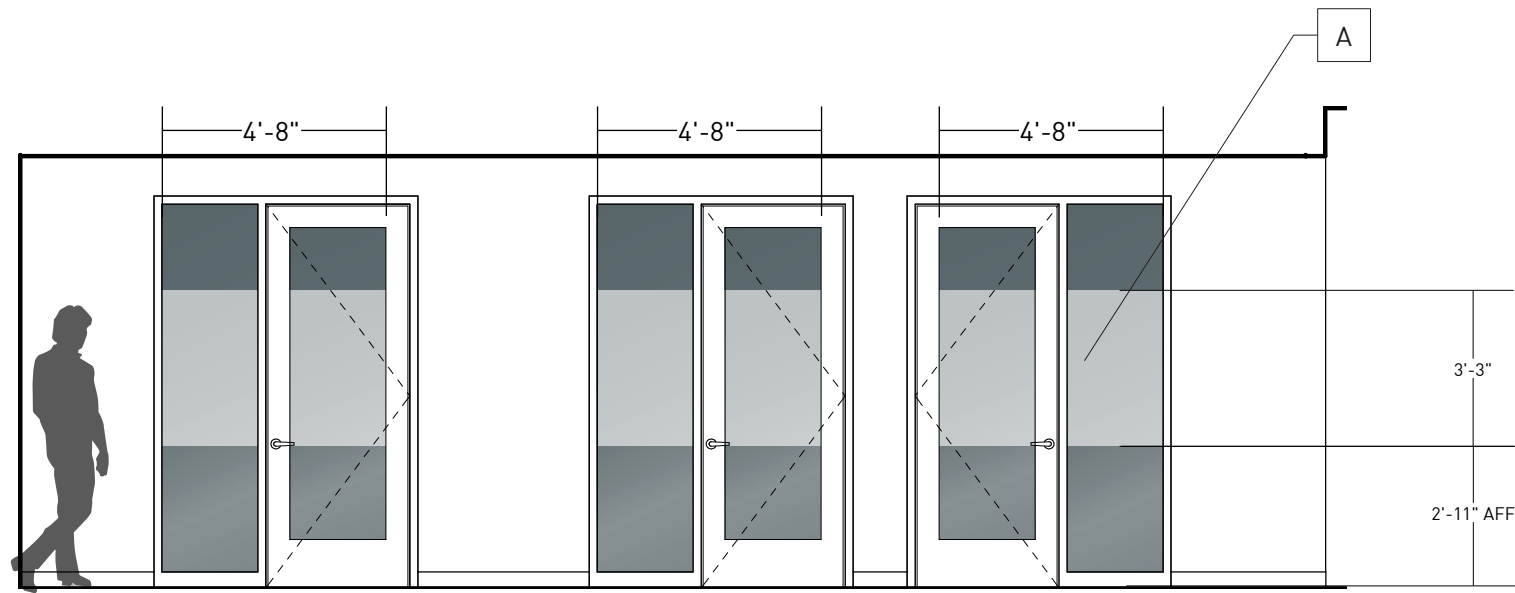

1 Elevation E.18 Window Vinyl
Scale: 1/4"=1'-0"

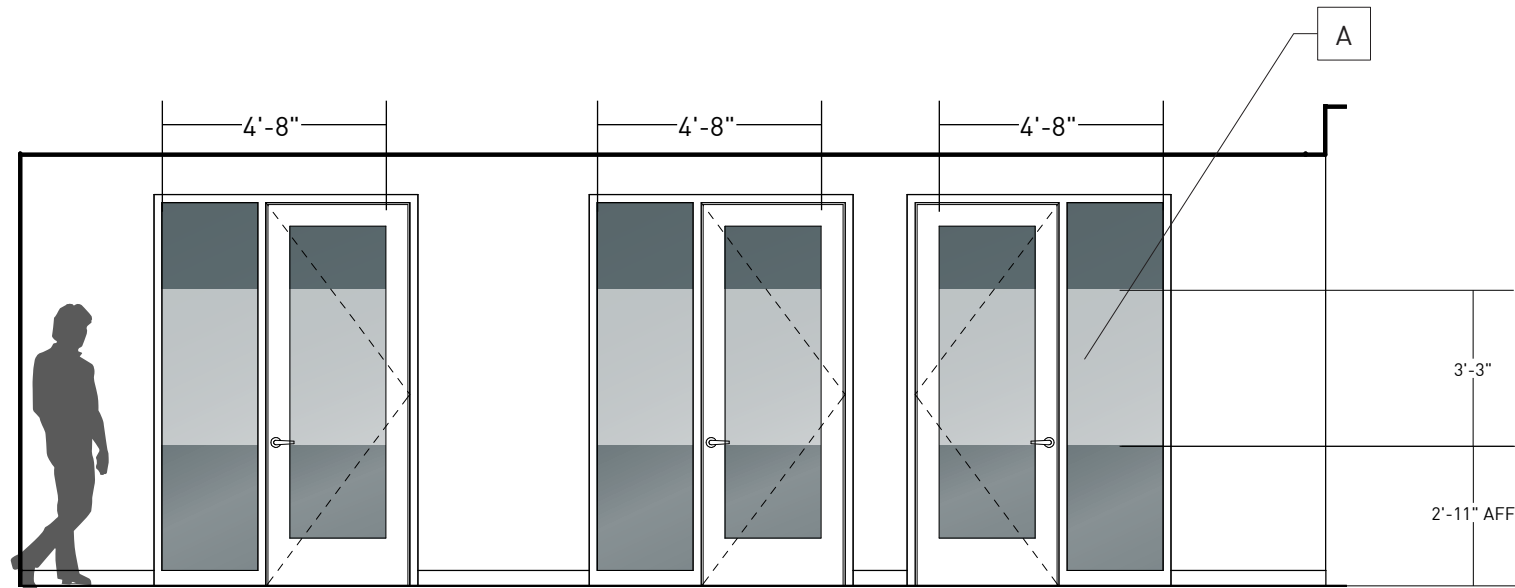

2 Elevation E.36 Window Vinyl
Scale: 1/4"=1'-0"

ELEMENT DESCRIPTION:

A
3M Dusted Crystal Vinyl, applied second surface

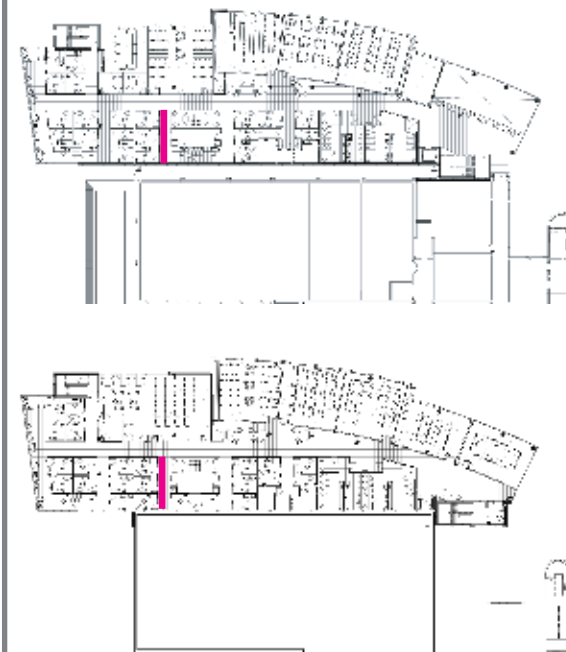

ELEVATION: E.20, E.38 & E.49 Window Vinyl Floor Two, Three & Four

SCALE: 1/4" = 1'-0"

ELEMENT DESCRIPTION:

A
3M Dusted Crystal Vinyl, applied second surface

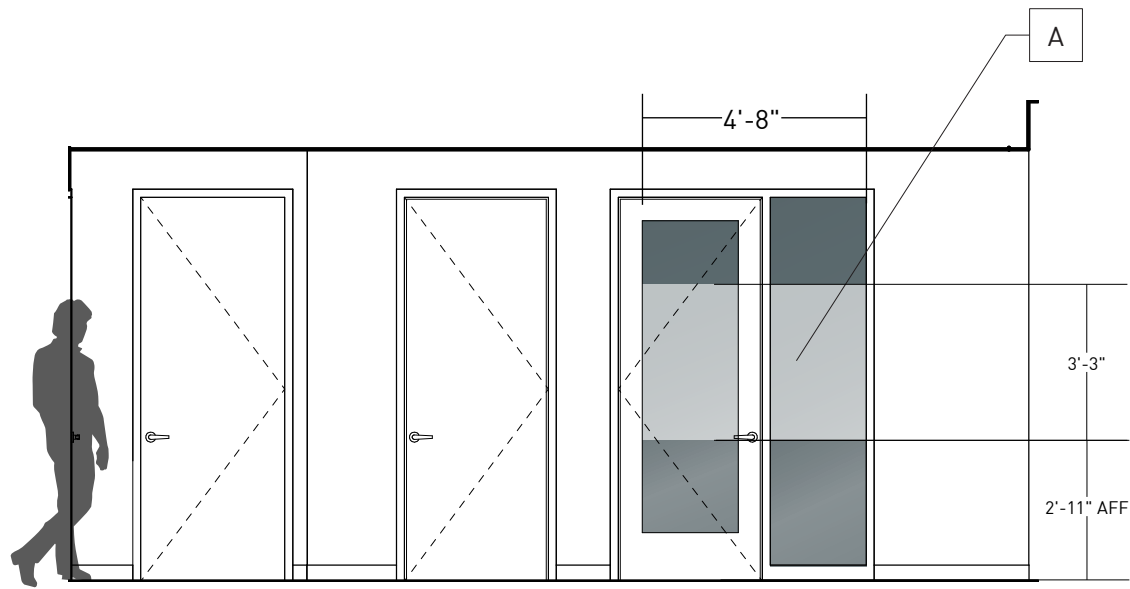

1 Elevation E.20 Window Vinyl
Scale: 1/4"=1'-0"

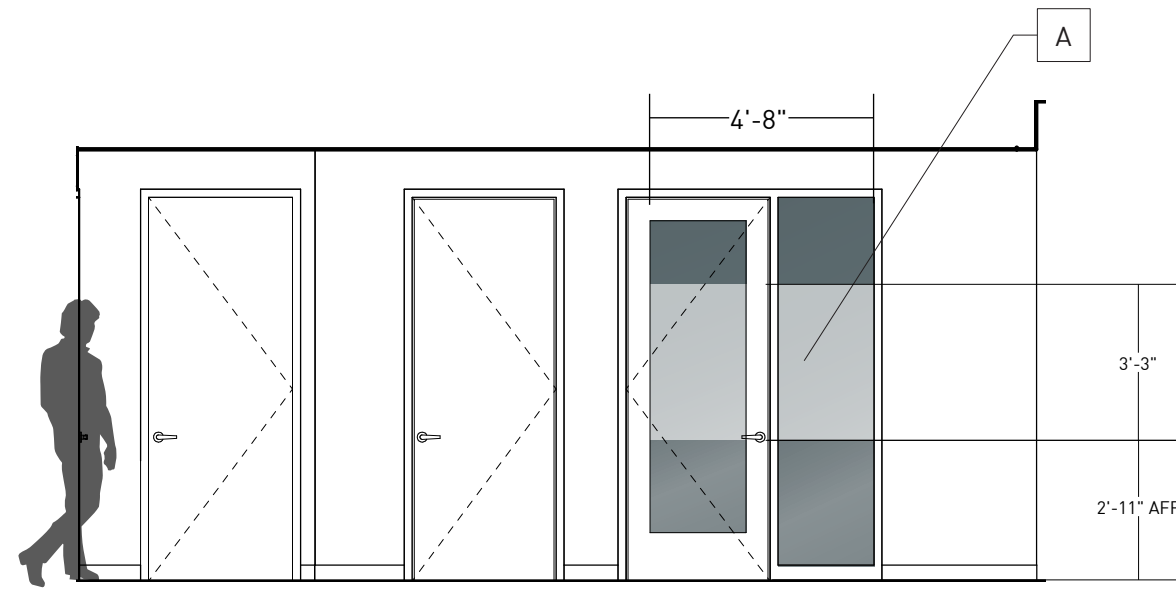

2 Elevation E.38 Window Vinyl
Scale: 1/4"=1'-0"

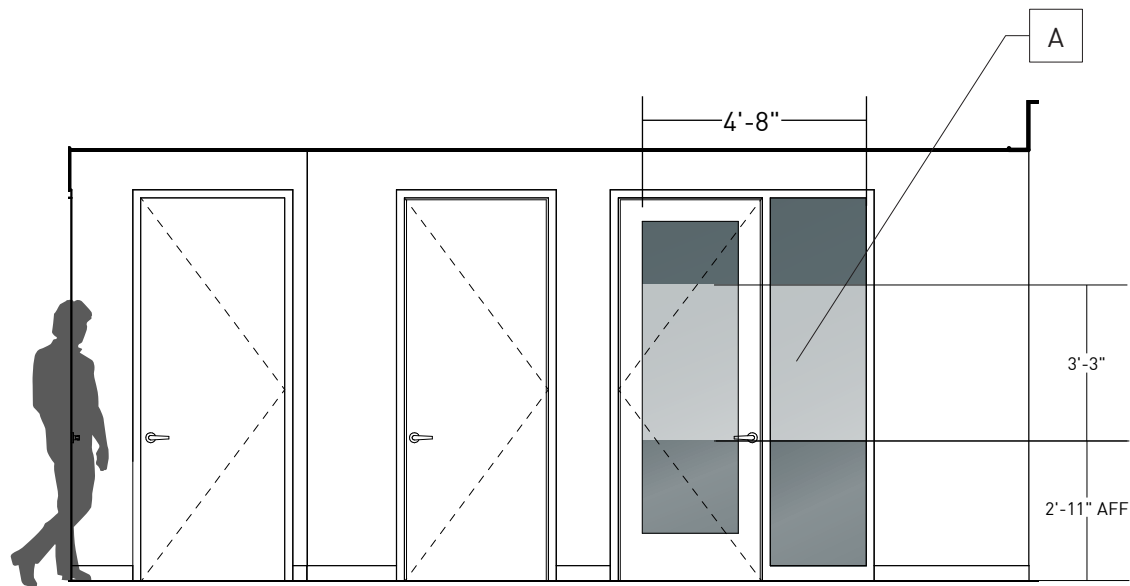

3 Elevation E.49 Window Vinyl
Scale: 1/4"=1'-0"

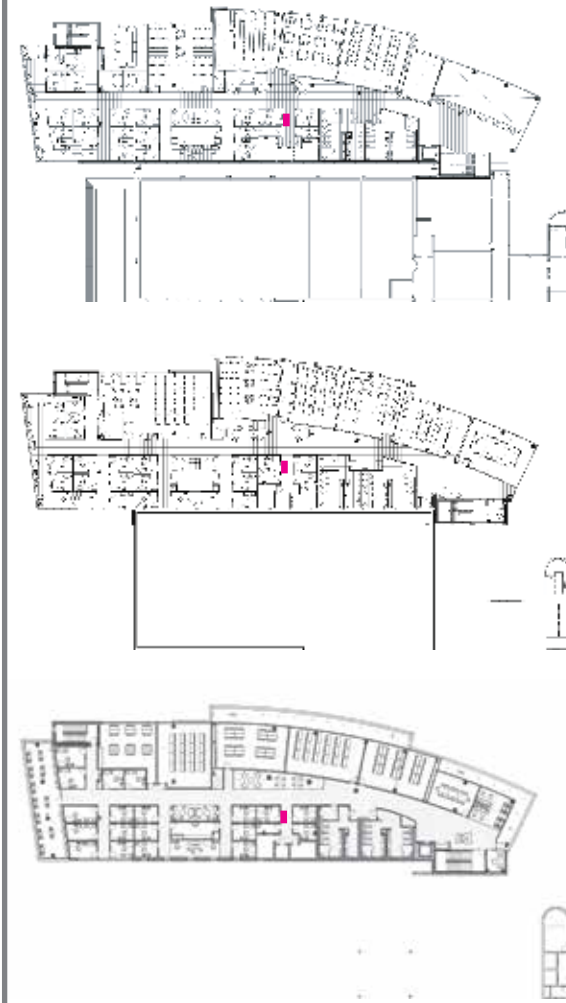

ELEVATION: E.21, E.39 & E.50 Window Vinyl Floor Two, Three & Four

SCALE: 1/4" = 1'-0"

ELEMENT DESCRIPTION:

A
3M Dusted Crystal Vinyl, applied second surface

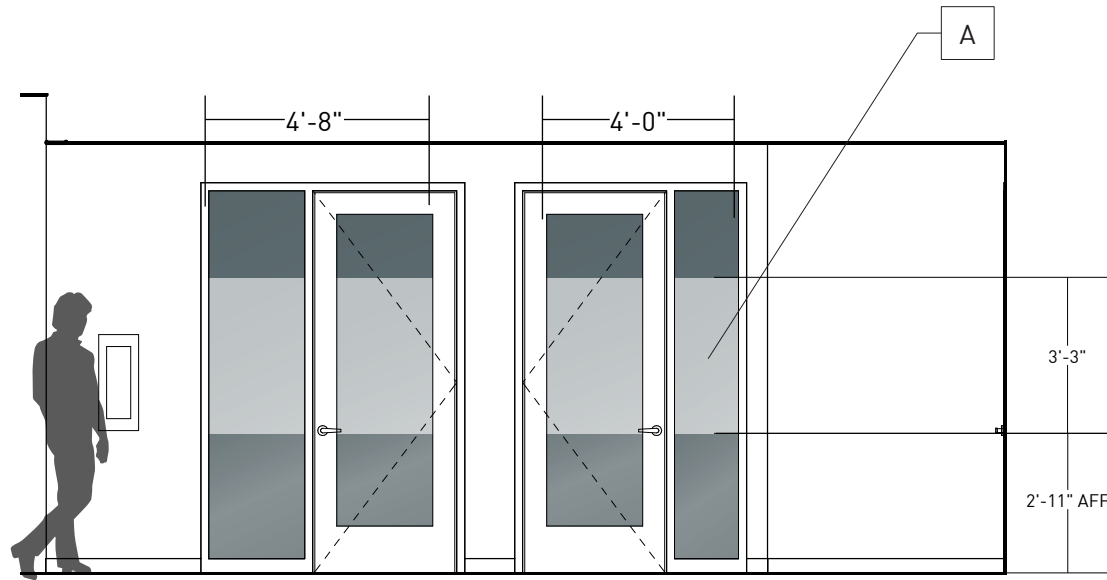

1 Elevation E.21 Window Vinyl
Scale: 1/4"=1'-0"

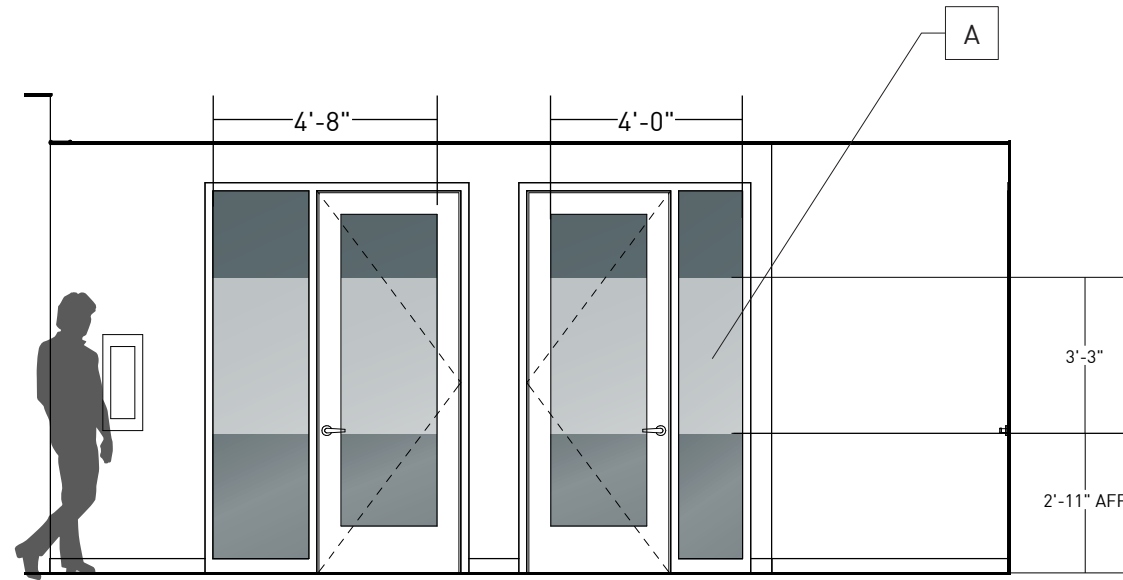

2 Elevation E.39 Window Vinyl
Scale: 1/4"=1'-0"

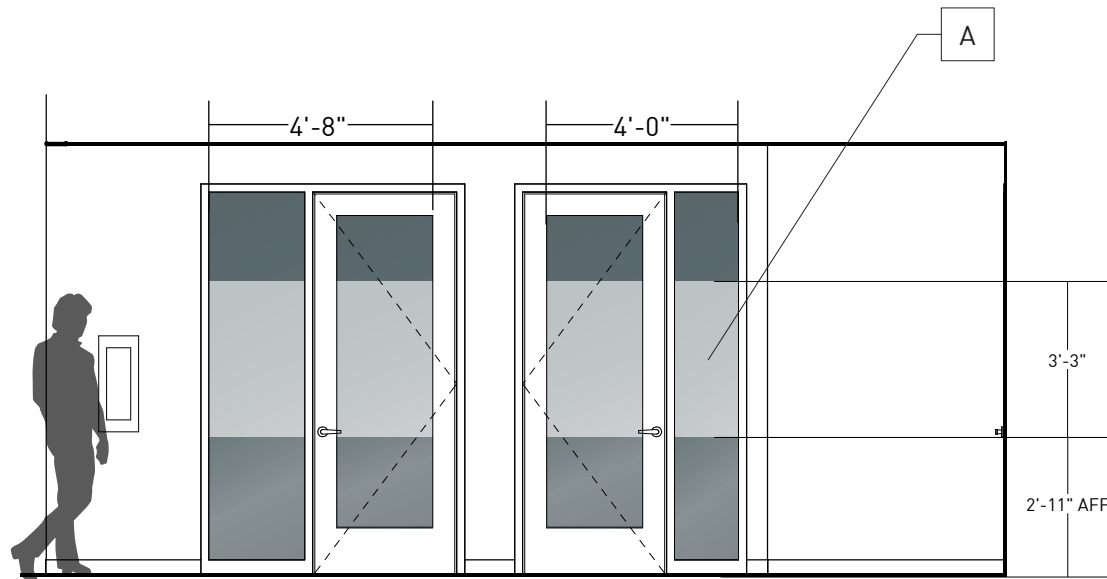

3 Elevation E.50 Window Vinyl
Scale: 1/4"=1'-0"

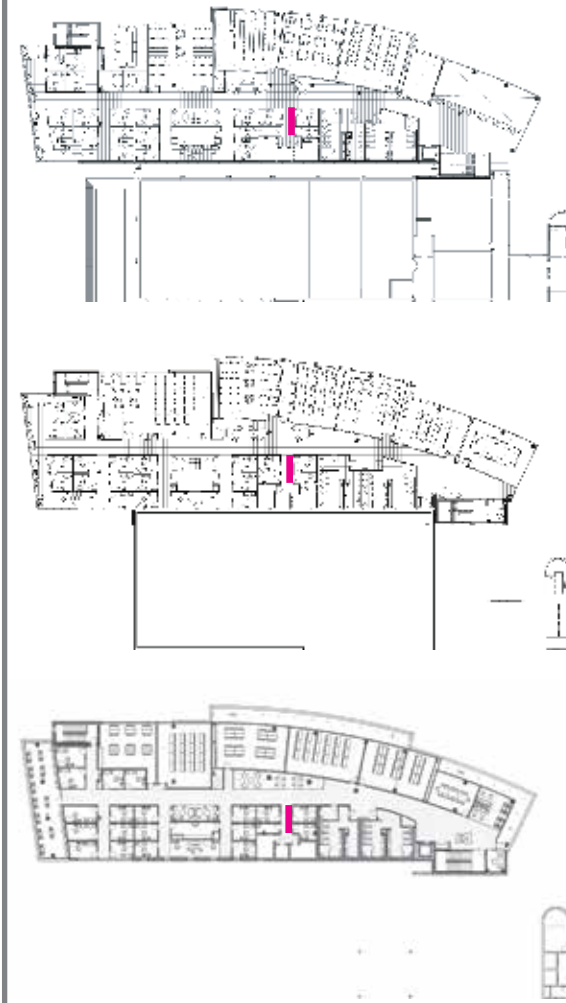

BHDP

Design for **People**